

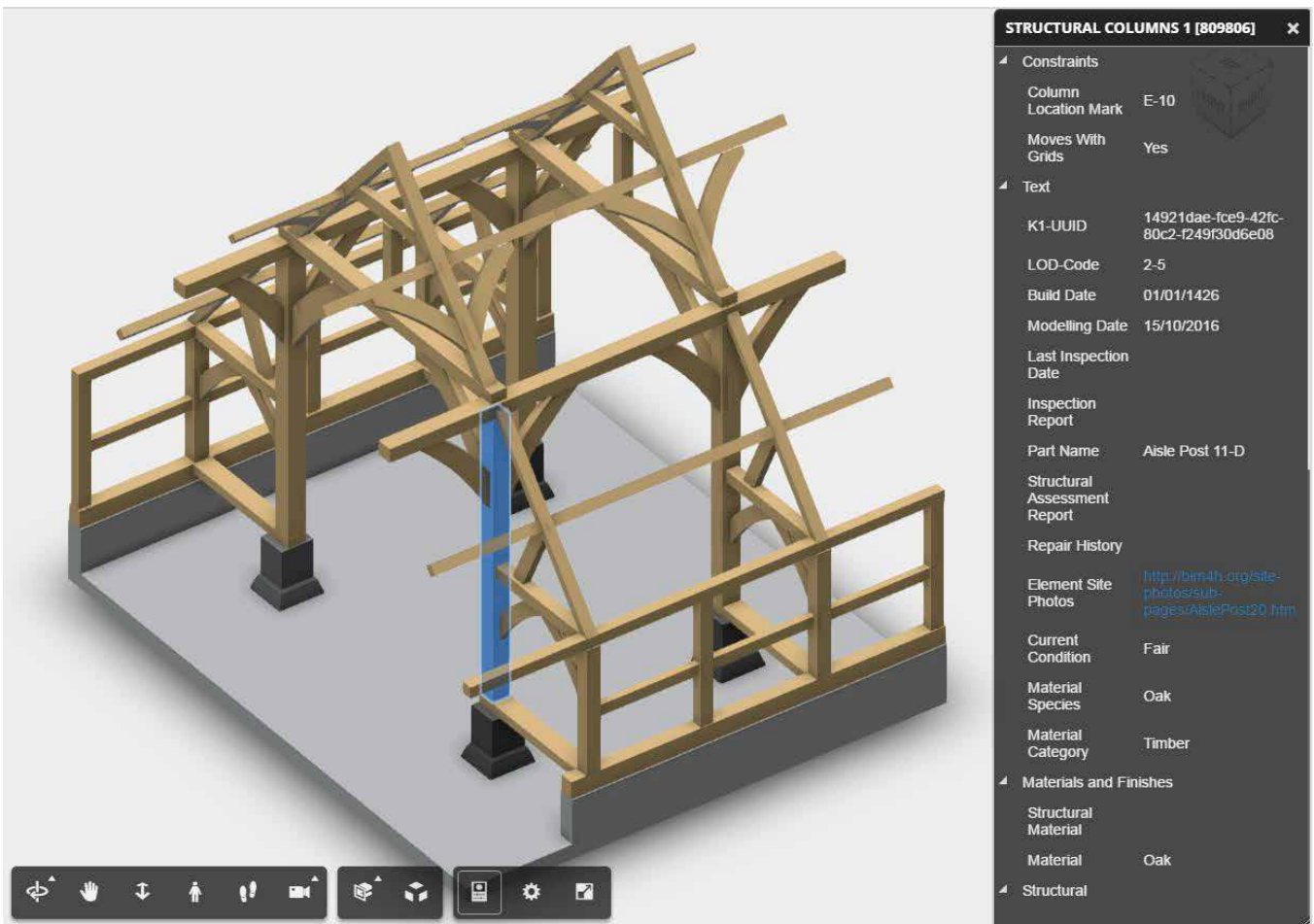

Historic England

# BIM for Heritage

Developing a Historic Building Information Model



# Summary

This publication on Building Information Modelling for heritage (Historic BIM) offers guidance for owners, end-users and professionals in the fields of heritage and construction. By raising awareness of the potential advantages of a BIM approach, this guidance will help users successfully implement BIM in heritage projects.

Historic BIM is, by definition, a multi-disciplinary process that requires the input and collaboration of professionals with very different skillsets. It is also a fast-developing field in terms of research, official guidance, standards and professional practice. This publication addresses the issues surrounding the production and use of BIM for historic buildings, and provides information about guidance and standards available elsewhere for managing a building's entire life cycle effectively.

This document has been prepared by Sofia Antonopoulou, Dipl-Ing Arch, MSc Arch Cons, and Paul Bryan BSc, FRICS.

Published by Historic England July 2017.  
All images © Historic England unless otherwise stated.

Please refer to this document as:  
Historic England 2017 BIM for Heritage: Developing a Historic Building Information Model. Swindon. Historic England.

<https://historicengland.org.uk/advice/technical-advice/recording-heritage/>

---

## Front cover

Harmondsworth Barn was built in 1426 and is an outstanding example of medieval carpentry containing one of the largest intact, timber-framed interiors of its era. Located in the village of Harmondsworth, just north of Heathrow Airport, it was dubbed the "Cathedral of Middlesex" by Sir John Betjeman.

In 2016 an example BIM model of the barn was generated as part of the HE funded research project "The application of Building Information Modelling (BIM) within a heritage science context". This model was developed to Level of Detail (LOD) 2 with representative geometry of each major part of the barn structure and sample metadata for several elements in the model.

# Contents

- 1 Introduction .....1**
  - 1.1 Building Information Modelling .....1
  - 1.2 Historic BIM .....2
  - 1.3 What BIM is not .....5
  - 1.4 The BIM mandate.....6
  
- 2 How BIM Works .....8**
  - 2.1 Historic BIM application.....8
  - 2.2 Data acquisition.....11
  - 2.3 Modelling approaches.....14
  - 2.4 BIM as a process for better information delivery.....19
  
- 3 Managing BIM Data.....23**
  - 3.1 BIM infrastructure .....23
  - 3.2 Standards and protocols.....26
  - 3.3 Dealing with the data .....27
  
- 4 Commissioning BIM.....29**
  - 4.1 Knowing what you want.....30
  - 4.2 Developing a BIM strategy.....31
  - 4.3 Assessing supplier capability.....31
  - 4.4 Legalities .....32
  
- 5. Helping You Decide.....33**
  - 5.1 Are you required to procure/deliver a project using BIM? .....33
  - 5.2 How could you benefit from adopting BIM on a heritage project? .....33
  - 5.3 Who will be responsible for maintaining the AIM?.....34
  - 5.4 Can you do this yourself? .....34

## Case Studies

CS1	A1 Leeming to Barton Project: Fort Bridge.....	35
CS2	Edinburgh Waverley Railway Station .....	38
CS3	Woodseat Hall.....	41
CS4	The Oriental Club.....	44
CS5	The Integration of Meshed Elements in a 3D BIM-ready Model.....	47
CS6	Measured Building Surveys to BIM .....	50
CS7	Public Areas and External Façade Laser Scanning and Revit Modelling.....	53
CS8	IWM Lambeth Road Laser Scanning and Modelling .....	56

## 6 Where to Find Out More .....59

6.1	Standards and guidance .....	59
6.2	Organisations and special interest groups.....	60
6.3	Publications .....	62
6.4	Further online resources .....	63

## 7 Glossary .....64

## 8 References.....68

## 9 Acknowledgements .....70

# 1 Introduction

## 1.1 Building Information Modelling

The term Building Information Modelling (BIM) is used to describe a collaborative process for the production and management of structured electronic information. BIM is not new technology, its origins being in object-based parametric modelling applications for mechanical systems design in the 1980s. BIM has been in use for the last 20 years in the architectural, engineering and construction (AEC) industry, and is now widely applied in the UK and internationally, mainly in the new-build sector (building and infrastructure).

**Note:** BIM technology involves the use of parametric objects assembled to provide a virtual representation of a building or facility (asset). Parametric BIM objects represent various architectural features, structural elements, systems, other components and spaces, and are intelligent carriers of information. Parametric objects are created using geometric definitions, associated data and rules that define their behaviour, ie how they interact with other objects or respond to changes in their parameters. In parametric modelling, changes in design will automatically update the assembly and its components so that rules and object definitions are always valid. In a BIM environment, all views of the assembly [two-dimensional (2D), three-dimensional (3D) and schedules] are coordinated; therefore, any changes are automatically reflected in all views, resulting in the consistent production of construction information. In this way, BIM technology combines the advantages of 3D digital geometric representation with a detailed understanding of how a building is constructed and how it performs.

BIM provides a methodology for better information management on design and construction projects, with eventual handover of the full information required for the operational stage. BIM can be used for a variety of applications, including:

- assessing design options
- clash detection
- quantities and cost estimation
- construction simulation [four-dimensional (4D) modelling]
- energy modelling
- manufacture and off-site construction
- project management
- facilities and asset management.

In the case of new-build projects, BIM offers a robust framework for a multi-disciplinary collaborative process of information production and exchange, resulting in the creation of a reliable, shared, knowledge resource to be used as the basis for decision-making, communication, planning and consultation. The problem of poor construction information – incomplete, inaccurate or ambiguous – has been identified as one of the key factors responsible for additional capital costs, delays and inefficiency in the construction sector. BIM offers a framework for better information management through the integration of digital technologies and collaborative working processes, applied across different sectors of the construction industry using common standards. The aim is to produce better value-for-money

services for the client, by reducing project risk and increasing efficiency. BIM processes enable more efficient methods for designing, delivering and maintaining physical built assets throughout their entire life cycle, from earliest conception to demolition. The benefits of BIM implementation in construction projects therefore include:

- efficient collaboration within a multi-disciplinary project team
- better design and construction coordination
- better cost estimation and planning
- better construction planning, including the possibility of off-site prefabrication
- reduced costs during construction (reduced delays on-site, less rework, fewer requests for information) and operational (seamless delivery of information for facilities management at handover) stages
- improved carbon performance.

The benefits of BIM for the architectural, engineering, construction and operation (AECO) industry are well known, but how well it can be applied in the heritage sector is still open to question, partly because of the diversity of projects that involve historic buildings and sites, such as conservation and refurbishment, adaptive reuse, preventative maintenance, heritage management, interpretation, documentation and research. Published case studies, such as the Manchester Town Hall conservation project, have shown that historic building conservation projects delivered using BIM can yield benefits during capital expenditure (CAPEX) and operational expenditure (OPEX) stages analogous with the new-build sector. Results from academic research of Historic BIM (the use of BIM for heritage and archaeology) are also very promising with regard to BIM implementation for heritage research and investigation. One of the aims of this publication is to raise awareness of Historic BIM both within the field of cultural heritage and also within the AECO industry.

## 1.2 Historic BIM

Unlike the new-build construction sector, where BIM has been applied widely for a number of years at an international level, with scores of relevant publications and online content, BIM for heritage assets (historic buildings and sites) is a relatively new field of academic research and appears less popular in terms of adoption by heritage professionals.

**Note:** The terms heritage BIM, Historic Building Information Modelling, HBIM, BIM for heritage and BIM for historic buildings have been used almost interchangeably. For the sake of consistency, the term Historic BIM will be used throughout this publication when referring to any use of BIM for heritage and archaeology, including applications for documentation, research, conservation and asset management.

**Note:** The world of BIM is full of abbreviations and acronyms, which can be confusing or discouraging at first contact. Several free and comprehensive resources are available online, such as the British Standards Institution (BSI) BIM Level 2 glossary and the BIM Dictionary (see [sections 6.1.2](#) and [6.4.2](#)), which can help clarify BIM terminology.

### 1.2.1 Managing cultural heritage information

Heritage projects typically rely on multi-disciplinary collaboration: a number of experts and specialists contribute, exchange and interpret complex information and data about a heritage asset to inform the understanding of its value and significance. This understanding is crucial for decisions on future interventions, conservation and management. British Standard (BS) 7913:2013 *Guide to the Conservation of Historic Buildings* (BSI 2013a) states that ‘research and appraisal into the heritage values and significance of the historic building should be carried out to ensure that decisions resulting in change are informed by a thorough understanding of them’. As noted in *COTAC BIM4C Integrating HBIM Framework Report Part 1* (Maxwell 2016a, 13–16), the quality of information for this multi-disciplinary knowledge base is crucial for heritage projects. Poor information (inaccurate, incomplete or uncoordinated) often leads to errors, which can be detrimental to the historic asset, its value and significance.

At present, information about historic buildings and (archaeological) sites is usually represented as a collection of individual documents, reports, drawings, computer-aided design (CAD; 2D or 3D) files and various datasets provided by different professionals, each working with their own tools and standards. Information about a single historic asset can be dispersed across a number of locations (electronic data repositories, databases and physical archives) and in various formats (paper and electronic). The status and quality of individual pieces of information may be unknown (superseded, uncoordinated or incomplete). In many cases, there is no single source of reliable and consistent information about a heritage asset.

**Note:** Organisations dealing with a large portfolio of historic assets, or even single-asset owners/managers, may be using different types of enterprise systems [eg asset management system, facilities management system, geographical information system (GIS)] to manage information about their estate/asset. These should contain coordinated and verified information about the asset(s) but are not usually associated with 3D geometry.

### 1.2.2 BIM as a solution for historic information management

As BIM is capable of incorporating both qualitative and quantitative information about a built asset to represent physical and functional characteristics, it can provide simulations of the appearance, development and performance of an asset. Intangible characteristics, such as heritage values and significance, can be integrated into the 3D model in a structured and consistent way, which allows easy information extraction and the production of deliverables. However, a systematic approach is needed when deciding, at the outset, what elements are essential (Maxwell 2016b) in order to avoid an excessively complex situation .

By incorporating high-quality digital survey datasets, BIM not only represents the appearance of the existing historic fabric, but also allows the exploration and complex analysis of proposed interventions in various scenarios. BIM offers a framework for collaborative working processes and sharing of coordinated datasets across a multi-disciplinary team, which makes it ideal for heritage conservation, management and research. BIM processes can be applied to ensure the creation of a reliable knowledge base about a heritage asset. If maintained, a historic asset information model can be an invaluable decision-making and management tool for the asset throughout its life cycle.

### 1.2.3 Applications of BIM in the heritage sector

In the new-build and infrastructure sectors, BIM has shown potential benefits within design and construction projects, with significant gains in the operational stage. The key factors are efficient multi-disciplinary collaboration, structured information sharing, and integration of facilities management requirements into early project stages. Construction projects in the heritage sector (conservation refurbishment, adaptive reuse, extension and repair) could similarly benefit from the adoption of BIM and collaborative working processes, with increased efficiency, reduced costs, better planning and improved carbon performance for historic buildings and sites. BIM technology allows improved spatial coordination and assessment of design options under various scenarios; this is arguably more important in the case of significant historic assets, where any change in the historic fabric must be carefully considered and justified.

**Note:** Part of the challenge is to integrate the BIM approach with existing, well-understood conservation criteria for determining significance and value, in addition to linking with other related initiatives such as the various professional architectural conservation accreditation schemes and the joint heritage agencies' requirements for compliance with these.

The heritage sector not only involves construction, but also planning, historic asset management, preventative maintenance, documentation, investigation and research. BIM can offer new tools for the sector to support all of these activities through digital collaboration and efficient information management. The 3D (geometry) and 4D (time-based) modelling capabilities of BIM technology can be useful for heritage interpretation, presentation and simulation applications.

Most modern BIM software includes the following features, which can be particularly useful in a range of heritage projects:

- multiple design options, for analysis of proposed interventions
- clash detection, for highly accurate spatial coordination of new interventions against the existing fabric
- phasing and 4D modelling, for analysis of historic building development
- integration of heterogeneous datasets, such as historic information, legacy data, photographs and drawings, geospatial datasets, geophysics and remotely sensed data and imagery
- integration of intangible information, such as significance and heritage values, associated with specific components or spaces
- interoperability, for data sharing and reuse across a multi-disciplinary team
- potential for interfacing with other enterprise systems, such as GIS, CAFM, databases and archives.

### 1.2.4 A central repository for all historic asset information

BIM allows the structured integration of both geometric and non-geometric information (including tangible and intangible values) as well as external documents into a single model, thereby becoming a central hub for all information relating to a historic asset. BIM can also simulate how a building performs under different scenarios and visualise different design options. In the case of historic buildings, information about building pathology, original materials and construction methods, material degradation and historic fabric developments can also be incorporated.



Historic BIM can be used for the following:

- to inform conservation
- as a heritage management tool
- as an archive and information resource, to aid future investigations and research.

Potential applications of BIM in the heritage sector vary according to the scope and purpose of a project, and include:

- forming an information repository for documentation and recording activities
- condition monitoring
- conservation planning
- preventative maintenance
- asset management (at both strategic and day-to-day operational levels)
- heritage management
- heritage interpretation
- visitor management
- intervention options appraisal
- work programming (conservation, repair, maintenance and reuse)
- construction simulation
- project management
- security, fire safety, visitor safety and health and safety (H&E) planning
- disaster preparedness.

BIM and collaborative working processes can be applied across a wide range of heritage projects that involve historic assets of different age, type and style. Some types of buildings or architectural styles lend themselves better to BIM in terms of the modelling process, for example when they involve repeatable components or distinct geometric shapes, and when information about them (materials, structure and performance) is available or easy to obtain. Examples include various buildings of neoclassical architecture, 20th-century modernist architecture and industrial heritage. BIM for other types of historic assets, such as medieval and vernacular architecture or archaeological sites, can be more complex. These issues are discussed in detail in section 2.

### 1.3 What BIM is not

BIM is sometimes incorrectly identified as a specific software package or a type of 3D digital model. However, BIM is not simply a newer version of 3D CAD or a 3D visualisation tool; it offers more than 3D modelling and digital documentation applications. Representing the appearance of an asset digitally through 3D modelling techniques does not solve the problem of information completeness and consistency, a major concern and efficiency barrier in the construction industry (including historic building conservation). BIM constitutes a technology-enabled, collaborative process for coordinated and structured information management. BIM introduces new processes to design and construction practice that can challenge traditional workflows of design and project delivery. At the same time, BIM offers an opportunity for modernisation, increased efficiency and integration of the heritage sector with the rest of the AECO industry.

## 1.4 The BIM mandate

The benefits of digital collaborative working processes and BIM for the construction sector have been recognised by the UK government, initially in the *Government Construction Strategy* (Cabinet Office 2011) and subsequently in the *Construction 2025* (HM Government 2013) documents. The 2011 government construction strategy (GCS) recognised the critical importance of an efficient construction sector to the UK economy and aimed to reduce the cost of public sector assets by up to 20% by 2016 (the GCS is also available on the BIM Task Group website; see [section 6.2.3](#)).

The GCS stated the government’s intention to request fully collaborative 3D BIM (with all project and asset information documentation and data being electronic) on all its assets as a minimum by 2016, aiming to reduce an estimated 20–25% of additional costs in construction projects caused by poor information management. This requirement for BIM Level 2 (see [section 1.4.1](#)) on all centrally procured public projects is commonly referred to as the UK government BIM mandate.

The BIM mandate only applies to public sector construction projects, but also aims to encourage BIM adoption in the private sector. There is no minimum project value specified in the GCS for the adoption of BIM in public sector procurement,

so long as there is a projected positive return on investment (ROI) and value in the data to be created. No distinction is made between new-build projects and those involving existing or heritage assets. In this sense, the UK BIM mandate is applicable to heritage conservation in the context of publicly procured projects (historic building conservation).

**Note:** The BIM mandate applies for central UK government: there are different policies in Scotland and Northern Ireland, and no explicit mandate for Wales. The Scottish government has declared its objective for BIM Level 2 adoption on projects across the public sector, where appropriate, by April 2017 (APS Group Scotland 2013). The appropriate BIM maturity level is decided using an online BIM grading tool and ROI calculator (see [section 6.2.12](#)). In Northern Ireland, BIM Level 2 is mandated for government centrally procured projects above the European Union (EU) procurement threshold, where there is potential for efficiency savings.

### 1.4.1 BIM maturity model

The concept of BIM maturity levels is used to describe the sophistication of information management processes within BIM projects. Four BIM levels (0–3) are defined according to the Bew–Richards BIM maturity model (Figure 1),

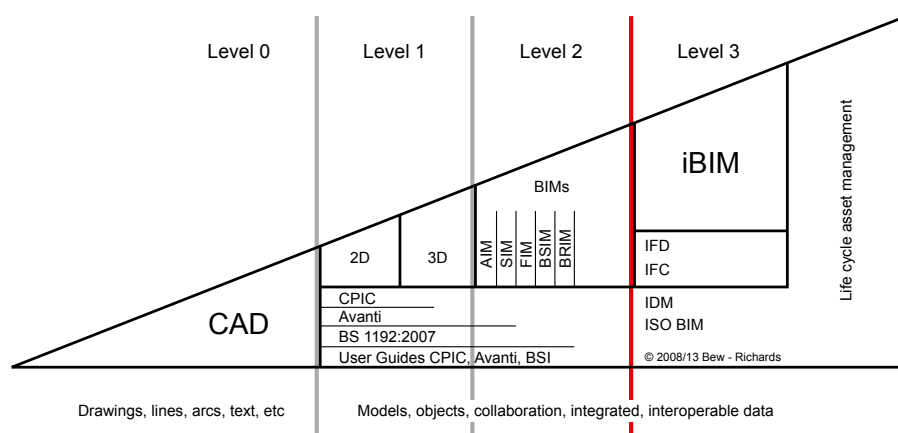

**Figure 1**  
The Bew–Richards Building Information Modelling (BIM) maturity model. The vertical red line corresponds to the UK government target for 2016.

which describes an entire spectrum of practice methodologies, ranging from uncoordinated paper drawings to fully integrated digital and collaborative workflows. The maturity model represents the progression of the construction industry towards fully collaborative information production, with milestones in the process defined as maturity levels.

There is some debate regarding the exact definition of each level of BIM maturity, but the following definitions are widely accepted.

- BIM Level 0 refers to the production of information in a non-collaborative way, using 2D CAD at most, with information output as uncoordinated paper or electronic documents.
- BIM Level 1 involves the production of information by each discipline separately using a mixture of 2D CAD and 3D modelling. Information in the form of electronic documents is shared within a common data environment (CDE), managed using BS 1192:2007 (BSI 2007).
- BIM Level 2 refers to a collaborative process of producing federated discipline-specific models, consisting of 3D geometric and non-graphical data and associated documentation. Information is exchanged using non-proprietary formats, such as industry foundation class (IFC) and construction operation building information exchange (COBie). BIM Level 2 requires all project and asset information, documentation and data to be electronic and managed within a CDE.
- BIM Level 3, also referred to as open BIM, represents a fully integrated methodology with collaboration of all disciplines on a single, shared, centrally located project model. This is the final step in the process towards collaborative information production. In level 3 BIM, the single source of information (shared model) ensures zero risk of conflicting information.

**Note:** Following the successful implementation of BIM Level 2, the UK government has declared its intention for public procurers and the construction industry to progress to BIM Level 3 on publicly procured projects between 2016 and 2025. More information is available on the Digital Built Britain website (see [section 6.4.3](#)).

#### 1.4.2 BIM and the UK heritage sector

Client and industry interest in BIM for construction projects on historic buildings, in part driven by the UK government BIM mandate, has resulted in growing activity by academia, professional institutions and heritage practitioners regarding the potential benefits of BIM implementation. Successful application of Historic BIM has been proven by a number of published case studies (from both academia and industry). Construction 2025 (HM Government 2013) included the Manchester Town Hall conservation project, one of the UK government's BIM pilot schemes, in a section on smart construction and digital design (Figure 2). Further examples of BIM implementation in heritage projects can be seen in Case Studies 1–8.



**Case study**  
The Manchester Town Hall Building project is one of the Government's pilot Building Information Modelling (BIM) schemes and has proved how valuable digital engineering can be during preconstruction and production delivery stages: saving money on unnecessary temporary works, saving the programme a total of nine months and demonstrating to the client BIM's potential for future facilities management purposes. Virtual 3D tours have educated key stakeholders, whilst also providing English Heritage with assurances that the building's heritage would be respected and protected.

**Figure 2**

The Manchester Town Hall conservation project showcases the potential advantages of Building Information Modelling (BIM) for design, construction and facilities management in a heritage context.

# 2 How BIM Works

This chapter describes the processes involved in creating a historic asset information model (AIM).

## 2.1 Historic BIM application

In simple terms, BIM can be described as a process of digitally illustrating all the elements that comprise a building, while in technical terms it is defined as object-orientated parametric modelling. In other words, the BIM process involves the assembly of 'intelligent' objects (building components and spaces) into a virtual representation of a building or facility (Figure 3). These consist of geometric (2D and/or 3D) and associated (non-geometric) information. BIM objects are parametric, defined using rules and automatically adjusting to changes in their context. Information is integrated within the model in a structured way, by adding the relevant pieces of information to corresponding BIM objects. In this way, BIM constitutes a digital information resource for the built asset.

**Note:** According to the publicly available specification (PAS) 1192-2:2013 (BSI 2013b), an information model is a (digital) model comprising documentation, non-graphical information and graphical information. The term asset information model (AIM) refers specifically to the information model used to manage, maintain and operate an asset. A project information model (PIM) is the information model developed during the design and construction phase of a project, which often forms the basis of the AIM.

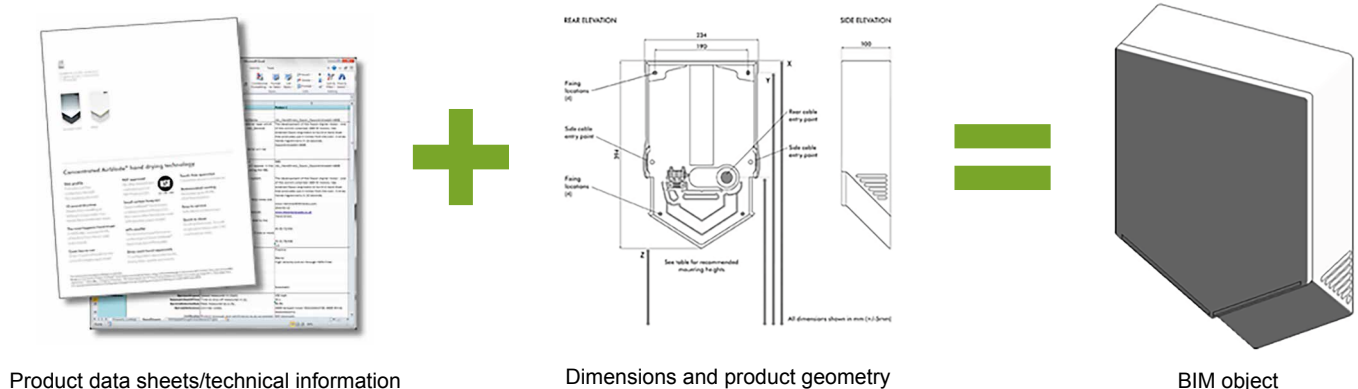

**Figure 3**  
Building Information Modelling (BIM) objects are parametric, intelligent components. They contain both geometry (two- or three-dimensional) and associated information. Object definition is based on a set of

parameters and rules, which define object behaviour. Source: National Building Specification (NBS) Library (see [section 6.1.4](#)).

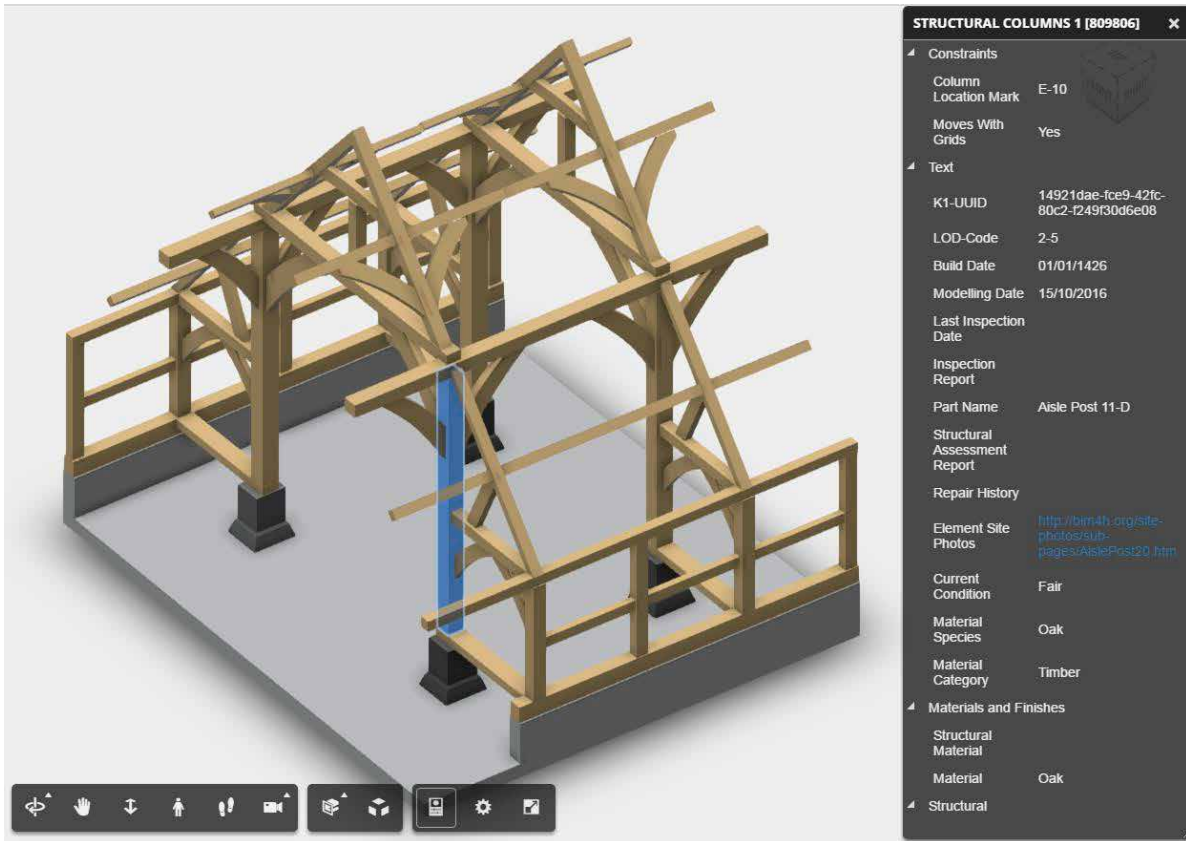

**Figure 4**  
Example parameter list for a Historic Building Information Modelling (BIM) object.

A BIM (and specifically Historic BIM) consists of:

- geometry (2D and 3D)
- non-geometric information
- linked documents and data.

The geometric model and its associated information are presented within the BIM software environment as 2D and 3D views, schedules and drawing sheets. Model views are coordinated, ie all views are constantly updated to reflect changes in the model. This ensures that information output from the model (in the form of drawings, schedules and visualisations) is always consistent.

Non-geometric information can refer to physical characteristics of the built fabric, such as materials, appearance and condition. It can include commercial, operational and maintenance information, such as manufacturer

and model names, warranty, maintenance and repair instructions, skill requirements, manuals, inspection dates, replacement cost, and H&E requirements. Non-geometric information can also refer to environmental, structural and mechanical performance, such as power consumption, disposal and recycling instructions, load-bearing capacity and standard compliance. In heritage, intangible information, such as cultural, historical and architectural values, and style, age and significance, can also be included in the model, attached to individual building components (eg a door) or spaces (eg a room).

**Note:** There is no definitive list of parameters (Figure 4) for BIM objects in a heritage project; some of the properties mentioned above will not be relevant, while others not mentioned may be of crucial importance. Decisions on the required parameters should be made on a case-by-case basis, according to asset type, project scope and objectives.





**Figure 5**

Geospatial datasets, such as point clouds, can be integrated into Historic Building Information Modelling (BIM) in order to represent existing fabric and/or be used as a basis for modelling.

BIM also supports the integration of geospatial datasets, to be used as a basis for modelling or as a baseline record of existing fabric; the use of a common coordinate system ensures spatial coordination. Geospatial datasets usually take the form of point clouds or (less often) triangular mesh objects (Figure 5). Information from other surveys and site investigations can also be integrated into the model or appended as external file attachments.

Apart from integrated data, any type of external digital file can be associated with the model, linked to elements (components or spaces) in a defined spatial hierarchy. These can include archival data, product specifications, operation and maintenance (O&M) manuals, reports, condition surveys, audio and video recordings (eg documenting visitor experience), inspection logs or any other type of digital file. The format of external files is not constrained by BIM software capabilities; linked files [using a uniform resource locator (URL) parameter definition] are opened in appropriate external applications, as determined by the operating system and/or user preferences.

BIM gives the option of organising all information relating to a historic asset (such as archival drawings, historic photographs and prints, written sources, recordings or any other type of digital/digitised file) into a spatial hierarchy. The information can be linked to spaces or building components that together constitute the full 3D model of the building. BIM then provides a hub for all the information relating to the historic asset, which can be queried intelligently and used for further investigation and research, conservation and management.

BIM software capabilities also allow users to undertake better analysis and decision-making through simulating how a building performs under different scenarios and visualising different design options, provided the relevant information has been included in the model. This is a crucial point: the required deliverables and applications (output) determine the information requirements (input). In turn, information requirements determine the data acquisition approaches and modelling strategies. This process (deliverables/needs determine requirements, which in turn determine the strategy) is sometimes referred to as 'starting with the end in mind'.

**Note:** The scope and objectives of the individual project and any organisational requirements on the part of the client will determine what types information are required, in what format, and when. Including more information than is relevant or useful for the project is wasteful: the additional volume of data also has implications in terms of information technology (IT) and information management requirements. Guidance and template documents can be helpful, but decisions must be made on a case-by-case basis.

## 2.2 Data acquisition

In cultural heritage, a BIM project will inevitably start at an intermediate point in the asset's life cycle (Figure 6), which can be much more complex than the relatively straightforward cradle-to-grave model that describes new-build construction, as shown in a report on Historic Building Information Modelling published by the Council on Training in Architectural Conservation (COTAC; Maxwell 2014) (see also [section 6.2.8](#)). The starting point for the Historic BIM process is a thorough knowledge of the existing asset. This is not because of any additional requirements of BIM, but rather a characteristic of heritage conservation regardless of the information management processes used.

In practical terms, the need to understand the historic asset in its present state translates into a requirement for significant initial input of information into the Historic BIM. While in the

new-build sector, new information is gradually generated through design and specification, in projects involving existing assets information must be retrieved from various sources, organised and validated, or created by different specialists.

For a historic asset, the necessary information and data may:

- be available and retrievable from various sources (archival information, operational data, maintenance plans)
- require survey, research and investigation (metric survey, specialist surveys, site investigations, heritage reports and assessments)
- be unavailable (because of budget, time, accessibility or other constraints).

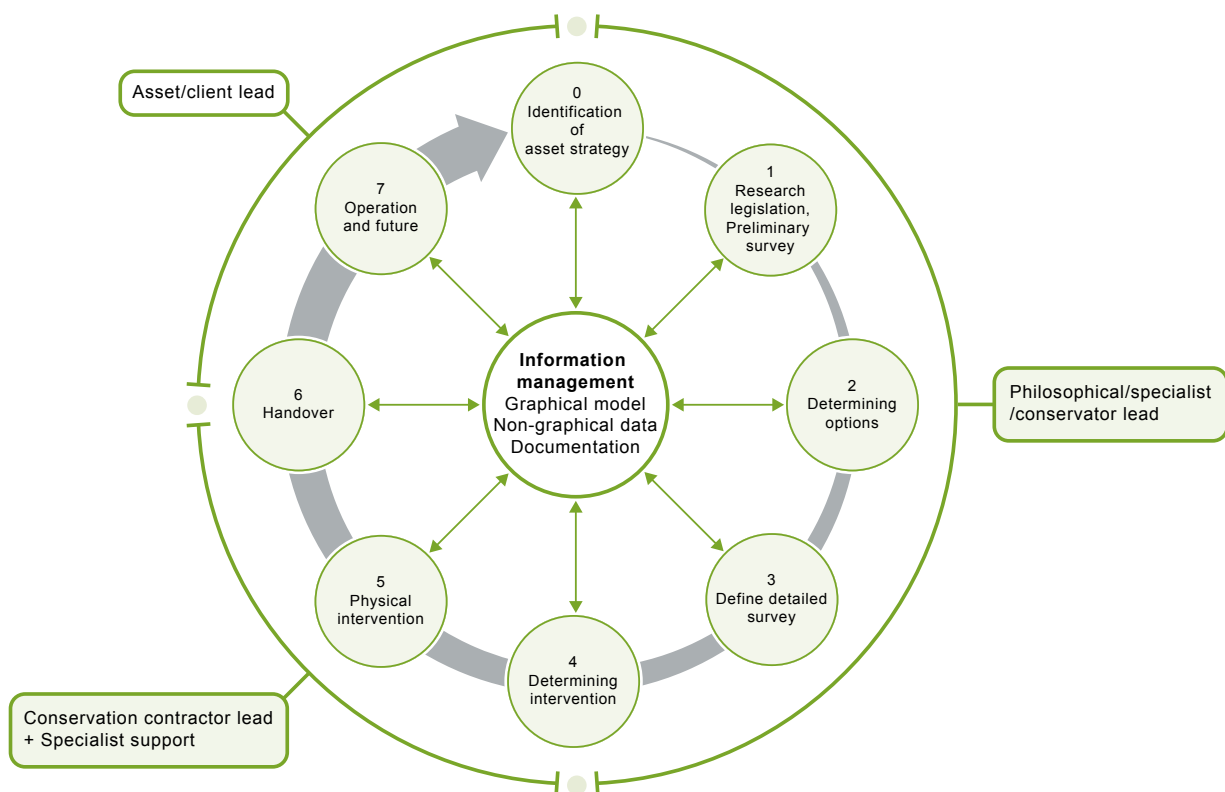

**Figure 6**  
The Historic Building Information Modelling (BIM) life cycle principle, adapted from the Construction Industry Council (CIC) cyclic BIM diagram to reflect conservation processes better.

### 2.2.1 Metric survey

Documentation of the existing fabric, paying particular attention to accurate metric data, is a prerequisite for heritage conservation. The representation of existing geometry in a 3D BIM environment also requires detailed and accurate knowledge of the physical shape of the historic asset. Historic BIM should be based on accurate as-existing metric survey datasets (preferably 3D), which document the position, size and dimensions of all visible surfaces, components and context of the historic asset, referenced to a local or national coordinate system. A (metric) survey programme is usually included in the early stages of a Historic BIM project.

Three-dimensional digital survey techniques are fast, reliable, non-contact methods for obtaining metrically accurate 3D data, and have been used extensively to document historic buildings and sites. Laser scanning, photogrammetry (ground-based or mounted on a drone), lidar, closer range scanning, mobile mapping or a combination of methods can be used to produce 3D datasets of the historic asset. These typically take the form of point clouds, which are now supported by most BIM software.

As well as 3D surveys, other survey sources can be used for BIM, such as measured building survey, 2D drawings or orthophotographs. These can be appropriate for projects that involve small or less complex sites, although coverage and adequate levels of detail may be difficult to obtain.

Historic England has published [technical advice documents](#) on surveying and recording heritage, including guidance on photogrammetry, laser scanning, lidar, geophysics, measured survey, landscape survey, global navigation satellite systems (GNSS) and plane table survey (see [section 6.1.3](#)).

Considerations such as the nature of the asset, time, accessibility, budget and other constraints will determine the survey technique(s) used. Factors to consider prior to undertaking or commissioning survey work for a Historic BIM project include:

- resolution/point density in relation to the required level of detail
- colour information
- coverage
- control and coordinate systems
- data formats
- metadata.

**Note:** Client requirements with regard to the survey process and deliverables should be documented in a survey specification document. Historic England provides guidance on this (Andrews *et al* 2015).

**Note:** The survey process should result in a reliable record of the existing fabric: its geometry, position and appearance. Survey datasets (point clouds or mesh surface models) do not constitute BIM, but they can be used as a reference and basis for modelling, as described in section 2.3.



### 2.2.2 Other investigations

Further investigations, qualitative surveys, desk-based assessments and site inspections can be required depending on the scope of the project and client requirements. Non-geometric data acquisition can include condition surveys, archaeological investigations, material analysis and other surveys [eg mechanical and electrical (M&E) systems], undertaken by appropriate specialists. However, to be fully successful in incorporating these potential gains and to assist in reading, understanding and interpreting what is happening beyond the visible surface, there is also a need to understand fully what is happening physically below ‘the surface’ of the asset that has been surveyed.

It is not necessary for these investigations to take place at the same time as the metric survey programme, although that may make sense in terms of site accessibility and logistics. Specialist investigations can be undertaken independently of other surveys, but taking into account the requirements of the information delivery programme.

### 2.2.3 Legacy information

The volume and quality of information available on a historic asset may vary greatly, depending on the type of building, previous use, ownership and management systems in place. Existing information may be in paper or electronic format, on-site or dispersed in several off-site locations, and potentially under intellectual property or security restrictions. The use of legacy information in a Historic BIM project is mainly determined by two qualities: accessibility and validity.

Accessibility is determined by where the information is stored, in what format, and whether there are any constraints on its use (ownership, security). Retrieving legacy information and ‘translating’ it into a format suitable for inclusion in BIM (eg digitising architectural drawings held in paper format) will have certain cost and time implications. Legacy information should then be validated before it is included in the model or used in the modelling process. Existing data can be superseded, incomplete, inaccurate, conflicting or ambiguous. It is essential to establish a process of quality control and validation for legacy data, as with any new work (eg survey specification). Such a process ensures that Historic BIM is always aligned with the current state of the physical asset or, if that is the purpose of the model, with its state at a previous stage in its development.

Often survey datasets already exist for a historic asset. However, these will not necessarily be appropriate as a basis for Historic BIM. Parameters such as accuracy, coverage, resolution, level of detail and coordinate systems will need to be compliant with the requirements of BIM. Moreover, any existing data should be validated on-site or against a new survey before being used in BIM.

## 2.3 Modelling approaches

BIM consists of (2D and 3D) geometry, non-geometric information and associated documents and data. Model creation (typically) starts with the geometry.

In the case of BIM for existing assets, including heritage, the model is created as an assembly of appropriate BIM objects, based on as-existing survey data. More specifically, the appropriate type of BIM component (eg wall, window) is selected, configured to the right dimensions (as evidenced by the survey data) and placed in the correct position.

### 2.3.1 Scan-to-BIM

The advantages of 3D geospatial datasets (eg point clouds obtained through laser scanning) for BIM are significant: large volumes of high-resolution data covering all visible surfaces of the subject (possibly with colour information) form a reliable basis for creating native 3D geometry in a BIM environment. The term ‘scan-to-BIM’ is used to describe these workflows, which involve a process of creating, manipulating and placing native BIM components by directly referencing the underlying point cloud.

**Note:** Scan-to-BIM workflows depend on the ability of BIM software to import point cloud datasets. Because of the ever-expanding use of laser scanning in the AEC industry, most recent versions of BIM authoring tools now include that feature (although ‘light’ versions of the same software may not). Supported formats for point cloud data can vary, depending on the choice of BIM software. Any issues around supported formats and software versions must be identified and resolved satisfactorily before the beginning of a project

The scope of scan-to-BIM processes can vary depending on project requirements. The result of scan-to-BIM is sometimes referred to as ‘BIM-ready’: a 3D model formed as an assembly of native BIM components, which represents the geometry of the existing fabric. Information and relevant data can be added to this model subsequently in a structured way, associated with the correct BIM elements (components or spaces).

### 2.3.2 Alternative approaches

BIM for existing structures does not necessarily have to be based on point cloud data. A number of published research projects on Historic BIM have applied a more conventional approach of creating models based on 2D CAD drawings. In some cases, this approach was selected even though laser scan datasets were available and used to validate the drawings. This can be an appropriate modelling approach, usually when the existing asset is simple in terms of geometry and adequately documented in CAD. It can also offer an alternative solution if the use of point cloud data is not an option because of IT (eg software version, hardware specifications), modelling skills, budget or other constraints. However, the level of (geometric) detail that can be achieved using this method may be lower than scan-to-BIM workflows.

### 2.3.3 Modelling tolerance and level of detail

Buildings of historic architectural styles often consist of highly complex geometries and ornamental features, which usually require more time to represent in detail than new-build architecture. This has implications for data acquisition (technology, time, budget), as complex geometries typically require more measurements and detailed (high-resolution) surveys to document at a level that allows them to be correctly interpreted and represented as 3D digital models.

Historic building components often include undefined shapes as a result of weathering or structural deformation, which is impossible (or very difficult) to represent accurately using parametric BIM objects. Moreover, buildings of certain historic styles (vernacular, medieval) typically include organic shapes, which again can be difficult or more time-consuming to model accurately using simple solid geometry.

These observations have direct implications for Historic BIM. The modelling process, despite advancements in scan-to-BIM tools and workflows (such as automatic geometry extraction), is still arduous and time-consuming. The time-effort input increases according to the degree of geometric detail in the model. Accurate and detailed representation of complex 3D geometry usually results in larger files, which are more difficult to work with and increase IT requirements. BIM software restrictions also make the use of native parametric objects for irregular geometries difficult or impossible to achieve without limiting model functionality. Two useful concepts are presented below, which will allow professionals and clients dealing with Historic BIM to communicate relevant requirements and define solutions: modelling tolerance and level of detail (LOD).



Modelling tolerance refers to how accurately a model fits against the as-existing survey (usually a point cloud dataset). Requirements in terms of modelling tolerance should be defined at the start of the project and form part of any scan-to-BIM specification. Tolerances can vary across different areas of the asset or for specific building systems/components, and can be expressed as a  $\pm$ mm figure. Modelling tolerances specify the maximum possible divergence of the model from what is considered to be the primary source of as-existing geometric information, for example the point cloud.

The acronym LOD is commonly used to describe the level of detail, ie how much geometric detail is included in BIM components. A BIM object can be modelled at different levels of detail, depending on project requirements. The LOD refers only to the appearance of the object (geometry), not the amount of associated information [sometimes referred to as level of information; the term 'level of model definition' is used in PAS 1192-2:2013 (BSI 2013b) to refer collectively to the level of detail and level of information in BIM]. For example, a component modelled at the lowest LOD (symbolic) can include full product specification. The required LOD for BIM of an existing asset has direct implications in terms of metric data acquisition, mainly for the resolution specification (point density for laser scanning).

In the case of geometrically complex objects, typical in heritage projects, high levels of detail and modelling tolerances may be possible, but often counterproductive in terms of file sizes and performance, as well as the time-effort input required. A clear specification for the LODs is required in order to avoid over-modelling. The perceived benefits (in terms of information quality and completeness, visualisation requirements, etc) should be carefully weighed against model functionality, file restrictions and time-effort.

**Note:** In order to be cost-effective, the minimum level of graphical detail sufficient for the purpose of the model should be specified.

There has been some work carried out towards LOD standardisation, such as the grading system proposed in *AEC (UK) BIM Technology Protocol* version 2.1.1 (AEC (UK) 2015) and the LOD framework proposed in *Metric Survey Specifications for Cultural Heritage* (Andrews et al 2015).

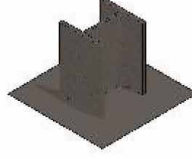
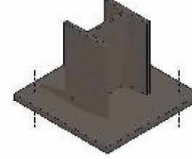
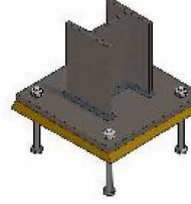
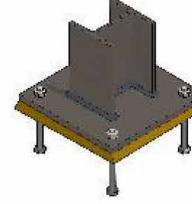
LOD 1	LOD 2	LOD 3	LOD 4	LOD 5	LOD 6
Symbolic	Conceptual	Generic	Specific	Construction	As built
					

**Figure 7**  
Level of detail (LOD) grades as defined in AEC (UK) BIM Technology Protocol version 2.1.1 (AEC (UK) 2015).

The LOD system proposed by AEC (UK) (2015) is aligned with the recommendations of PAS 1192-2:2013 (BSI 2013b) and proposes six levels of detail for BIM components (Figure 7). The system is not specifically targeted towards historic buildings, but it can be used to define and communicate the level of (geometric) detail required for models, systems, assemblies or individual components.

AEC (UK) BIM Technology Protocol (AEC (UK) 2015) defines LOD as different grades for component creation, as follows.

- LOD1 – Symbolic: Symbolic place-holder representing an object which may not be to scale or have any dimensional values
- LOD2 – Conceptual: Simple place-holder with absolute minimum level detail to be identifiable, e.g. as any type of chair. Superficial dimensional representation. Created from consistent material
- LOD3 – Generic: A generic model, sufficiently modelled to identify type and component materials. Typically contains level of 2D detail suitable for the “preferred” scale. Dimensions may be approximate
- LOD4 – Specific: A specific object, sufficiently modelled to identify type and component materials. Accurate dimensions. A production, or preconstruction, “design intent” object representing the end of the design stages. Suitable for procurement and cost analysis
- LOD5 – For Construction / Rendering: A detailed, accurate and specific object of the construction requirements and building components, including specialist sub-contract geometry and data. Should include all necessary sub-components adequately represented to enable construction. Used only when a 3D view at a sufficient scale deems the detail necessary due to the object’s proximity to the camera
- LOD6 – As Built: A precisely modelled representation of the constructed object. Any construction irregularities or eccentricities should be modelled’ (AEC (UK) 2015)

**Note:** PAS 1192-2:2013 (BSI 2013b) proposes the gradual refinement of model geometry and associated information in distinct levels corresponding to the Construction Industry Council (CIC) project stages. The alignment of levels of model definition with specific project stages fits well with new-build construction projects, but will not be equally applicable to existing assets.

Another framework for defining LOD specifically for heritage applications has been proposed in Metric Survey Specifications for Cultural Heritage (Andrews *et al* 2015) (Figure 8). This document defines four levels of detail.

- Level 1: basic outline of the building/structure represented as a solid object using representative component information but with no architectural detail depicted
- Level 2: outline of the building/structure represented as a solid object with principal architectural features included using generic components'
- Level 3: outline of the building/structure represented as a solid object with all architectural features and major service detail included using generic components
- Level 4: detailed survey of the building/structure represented as a solid object including all architectural detail, services and custom developed components to accurately represent fabric type' (Andrews *et al* 2015)

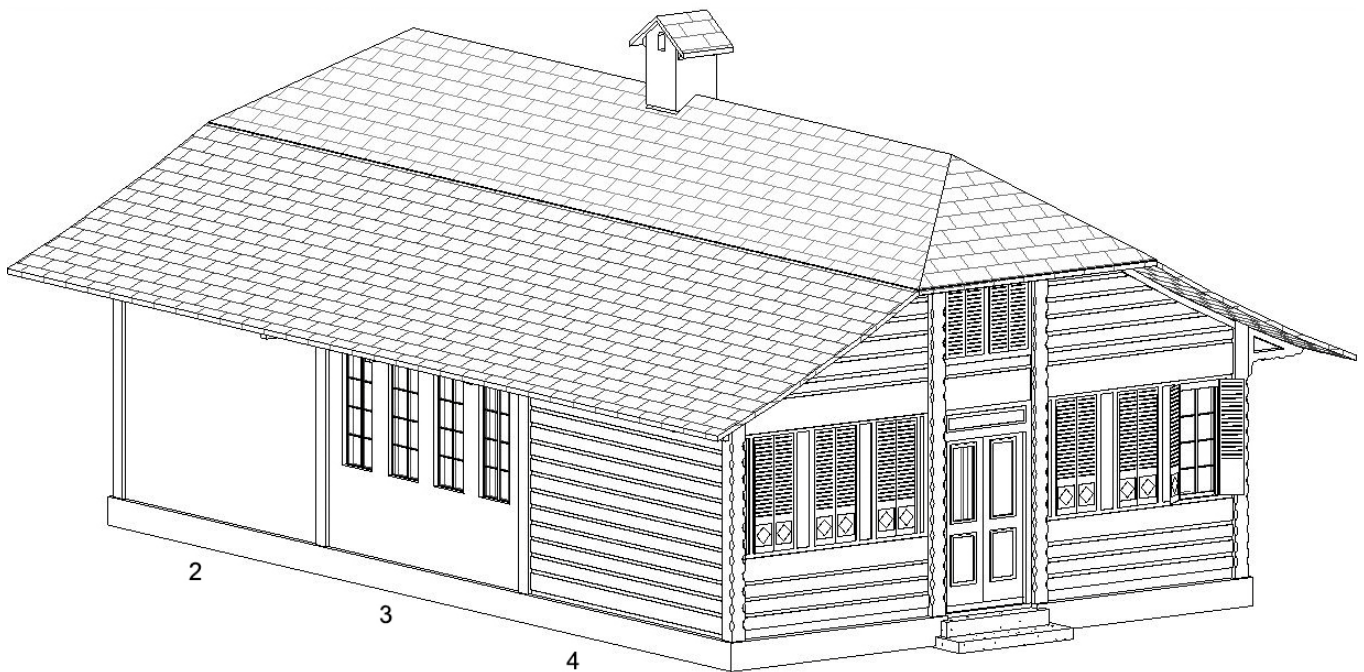

**Figure 8**  
Illustration of different levels of detail (LOD 2–4) as defined in *Metric Survey Specifications for Cultural Heritage* (Andrews *et al* 2015).

Alternative conventions can be used to communicate the required LOD for models or individual components in Historic BIM applications. A new Historic England report, [The Application of Building Information Modelling \(BIM\) Within a Heritage Science Context](#) (Brookes 2017) proposes such a system, which also relates model LOD to metric survey requirements. If there is any departure from widely accepted LOD conventions, the system used should be adequately defined and accompanied by illustrated examples.

**Note:** Levels of detail are different from levels of development (confusingly also given the acronym LOD), which were defined by The American Institute of Architects (AIA) for the *AIA G202-2013 Project Building Information Modelling Protocol Form* (AIA 2013). This framework recognises levels of development LOD100–LOD500, which are used to specify the degree of reliability of model information.

### 2.3.4 Custom content requirements

Unlike new-build architecture, which is usually characterised by uniformity and repetition, cultural heritage assets typically consist of non-standard, bespoke or unique building elements. Buildings of historic styles (eg neoclassical) also contain a number of repeatable components, which can be modelled as parametric BIM objects and form part of a project BIM content library.

BIM software packages usually include built-in libraries of standard objects, which are mostly suited to new-build design. A wide range of BIM objects is also available to download from various online repositories (see [section 6](#)). Historic building components are not usually found in standard object libraries, so custom content creation may have to be undertaken as part of a Historic BIM project. The resulting BIM library can be reused in projects involving similar assets.

**Note:** Although aimed at new-build design, the National Building Specification (NBS) National BIM Library (see [section 6.1.4](#)) can be of use to Historic BIM projects. It is an ever-expanding repository of BIM objects, available to download free of charge in proprietary or IFC format, all certified for compliance with the NBS Object Standard.

**Note:** There is ongoing research into the development of historic component libraries. There are also publications that detail how components for certain architectural styles can be modelled using BIM software (eg Aubin and Milburn 2013). These may be of interest to those working on content creation for buildings of historic styles.

### 2.3.5 Hybrid BIM

The components of cultural heritage assets are often unique and content-dependent. This may limit the usefulness of parametric modelling, which is the core of BIM technology.

Creating a detailed model of a unique element as a BIM object can be very time-consuming and expensive to complete. An alternative approach has been used in a number of case studies, involving surface geometry (mesh) created from geospatial data. This can be a relatively quick way to add complex geometry to a model, without the need to recreate the object as native BIM geometry. It can be useful for visualisations and (perhaps) analysis, such as interference checks and design options.

However, this is not an efficient method when applied to more than a few components. Integrating meshes increases model file sizes considerably, with implications for storage and processing speed. Also, mesh objects have limited functionality within BIM: non-native geometry is not parametric and cannot be edited easily nor does it interact well with other BIM components. There may also be restrictions on adding information to non-native BIM data (dependent on the choice of BIM software).



**Note:** Another approach that can be very cost-effective for conservation projects is to use geospatial datasets in the form of point clouds to represent the existing fabric, and only model new interventions as native BIM objects. This type of model can be described as ‘hybrid BIM’, as it does not have the full capabilities of BIM and restricts the range of possible analyses (Brookes 2017).

### 2.3.6 Incomplete/unavailable information

In Historic BIM projects some information is liable to remain unavailable because of budget, time, accessibility, physical or other constraints. For example, the material composition of existing historic fabric (hidden behind wall linings and later interventions) and its properties (eg structural and environmental performance) in most cases can only be assumed, unless targeted investigations take place. This is a significant departure from standard (new-build) BIM practice, where all information is (or should be) known, as it is created and refined through the various stages of a project.

Data voids (ie areas where no survey data has been captured) also fall within this category. Data voids have implications in the modelling process, where educated guesses may have to be made about certain aspects of the asset’s geometry. According to recommended BIM processes, all information (delivered/exchanged) must be verified and validated, allowing zero ambiguity. If any part of the model is based on assumptions because of data voids or incomplete information, this should be explicitly marked to avoid ambiguity and future confusion, misinterpretation and ill-informed decision-making.

**Note:** The model should therefore only include information of a known degree of certainty. It can be useful to establish a project-wide convention to mark instances where assumptions were made about the appearance or properties of an object.

## 2.4 BIM as a process for better information delivery

The previous subsections have outlined the characteristics of BIM as a digital 3D information model for heritage applications, and explained what Historic BIM is. However, BIM is not just a 3D model or a type of software; it is a process of supporting multi-disciplinary collaboration for better information management in building projects.

Successful building projects (construction, refurbishment, maintenance, management) depend on information that is complete, accurate and reliable. BIM and collaborative working processes offer a framework for managing information exchanges and maintaining the integrity of information throughout the project stages. One of the basic requirements of BIM for driving efficiency is that information is not duplicated, but shared and re-used within the project team. In this sense, interdisciplinary collaboration relies on interoperability and meaningful data exchanges.

It is generally accepted that a single BIM tool cannot cover every requirement of the design–construction–management process. Instead, project teams must establish more or less complex workflows that include several interrelated softwares. Different specialists should also be able to select the digital tools most appropriate to their task regardless of the software choices of other members of the team. These software systems are sometimes referred to as digital ecologies or digital software ecologies.

Digital ecologies rely on interoperability, the seamless flow of information across software platforms. However, in practice the translation of data from one digital format to another is not without its problems. Interoperability is facilitated through open-data exchange formats, which are developed at an international level and applied across all sectors of the AECO industry.

### 2.4.1 IFC

The IFC standard is an open-data exchange format for BIM data. IFC is a non-proprietary format, supported by most BIM software providers. It can be used across the construction industry for exchanging 3D building object-orientated design data, regardless of the BIM software used by other members of a project team.

**Note:** IFC is defined by ISO 16739:2013 (ISO 2013) for data sharing in the construction and facility management industries. The IFC set of standards is undergoing development in response to user requirements at an international level. More information is available on the BuildingSMART website (see [section 6.2.5](#)).

### 2.4.2 COBie

COBie is a data-exchange format, defined as a subset of IFC. COBie is intended mostly to facilitate the handover of information created during the design and construction stages of a project to facility operators. COBie information can be displayed in a neutral spreadsheet format and imported in facility/asset management systems.

COBie supports the exchange of information about both new and existing facilities (buildings and infrastructure) throughout their life cycle. Regardless of the software applications used to create, send, receive and interpret information, COBie ensures that information can be reviewed and validated for compliance, continuity and completeness.

**Note:** COBie is an international standard and the UK government's chosen information exchange schema for BIM Level 2, alongside BIM and associated documentation. The use of COBie in the AEC (UK) industry is outlined in BS 1192-4:2014 (BSI 2014a).

### 2.4.3 Classification systems

Classification systems for construction information (including facilities, activities, systems, components and products) are critical for processes such as data interrogation and information extraction. The consistent use of a classification system allows information about particular types of building components to be retrieved from a large dataset and queried quickly and efficiently. Approved heritage vocabularies, such as the Forum on Information Standards in Heritage (FISH; FISH 2017), can be consulted and incorporated. The use of classification systems for BIM data is included in COBie-UK-2012, as outlined in BS 1192-4:2014 (BSI 2014a).

There are differences in the preferred classification systems across industry sectors and in different countries, for example Uniclass in the UK and Omniclass in North America. Uniclass 2015 is the recommended standard in the UK and is intended to cover all construction sectors.

**Note:** The latest versions of Uniclass classification tables are available for download from the NBS website (see [section 6.1.4](#)).

### 2.4.4 BIM standards

In a collaborative working environment, the use of universally accepted standards is critical, as it ensures that the information produced and exchanged will be of a certain form and quality, which will eliminate ambiguity in its interpretation and use. A number of international and UK standards define the use of BIM in the construction industry. In the UK, recommended practices for collaborative BIM are outlined in a suite of documents (BS and PAS), which are all available to download free from the BIM Level 2 website (see [section 6.1.2](#)). These documents provide general (big-picture) recommendations with regard to BIM best practice as applied to both construction and operational stages.



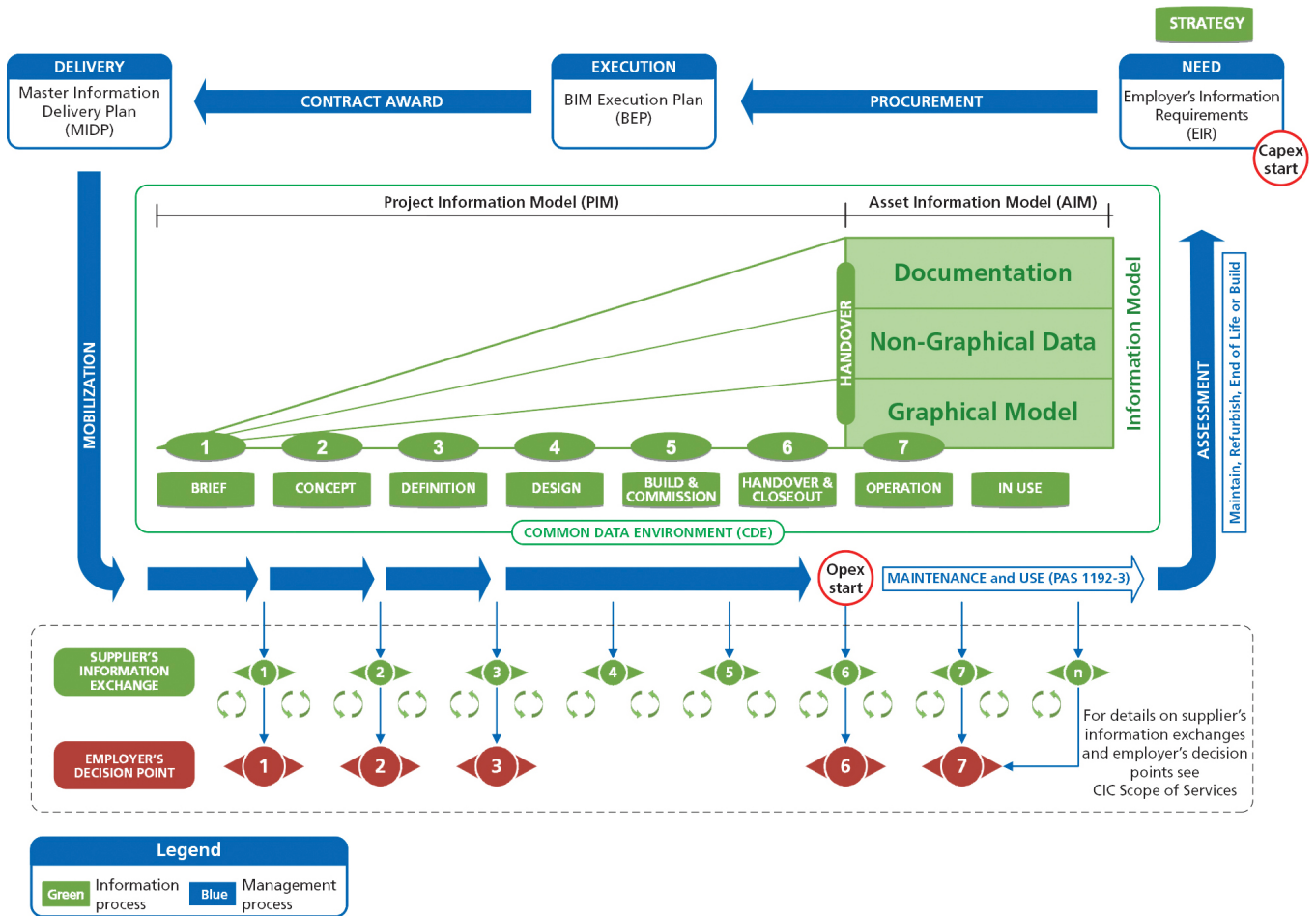

**Figure 9**  
The information delivery cycle diagram.

PAS 1192-2:2013 (BSI 2013b) describes the process of information production and exchange throughout the standard CIC project stages of design and construction with eventual handover into the operational stage (Figure 9). PAS 1192-2:2013 applies to both new-build and existing assets. In the case of new-build construction, the information delivery process commences with capital expenditure in the statement of employer information requirements (EIR). In the case of existing assets, BIM starts with an assessment process (within the operational stage). PAS 1192-2:2013 should be consulted in relation to conservation, refurbishment, extension, adaptive reuse or other construction projects involving historic assets.

Of particular importance to Historic BIM (as with any other project dealing with existing assets) is PAS 1192-3:2014 Specification for Information

Management for the Operational Phase of Assets using Building Information Modelling (BIM) (BSI 2014b) (Figure 10). This document outlines recommended BIM practices for asset management, explaining the processes involved in creating, maintaining and using an AIM, the single source of accurate information about an existing asset. The AIM can be created by inheriting information from a PIM, developed during a construction project and handed over to the operational stage, and/or by incorporating information from other sources (eg surveys, legacy data). In order for the AIM to be a useful tool for management throughout the life of the asset, it must be maintained, ie continuously updated to reflect changes in the physical asset. PAS 1192-3:2014 should be consulted in relation to historic asset management, including preventative maintenance, planning and other heritage management activities.

Collaborative BIM processes are underpinned by the recommendations of BS 1192:2007 (BSI 2007), which can be applied across the AECO industry. The use of a CDE to facilitate collaborative working processes is defined in BS 1192:2007 and developed further in PAS 1192-2:2013 (BSI 2013b) and PAS 1192-3:2014 (BSI 2014b).

There is ongoing debate about the suitability (or not) of existing BIM standards (as well as classification systems and data-exchange formats) to fulfil the particular requirements of heritage projects. These standards describe typical new-build project scenarios, but also make provisions for their application in the case of existing assets. Adopting existing BIM standards and specifications in heritage projects may not always be completely straightforward. There are currently no BIM standards specifically developed for the heritage sector.

Significant work towards the development of appropriate BIM standards for the conservation, repair and maintenance sector has been undertaken by the Council on Training in Architectural Conservation (COTAC), initially with the COTAC report Integrating Digital Technologies in Support of Historic Building Information Modelling (Maxwell, 2014) and later with the publication of two Historic BIM framework reports (Maxwell 2016a, b). These documents aim to integrate BIM standards originating in the new-build sector with key principles and guidance from the field of heritage conservation, such as BS 7913:2013 (BSI 2013a). Conservation influences are mapped across standard BIM processes, which are revised to accommodate the particular requirements of Historic BIM projects.

Standards are constantly being updated and expanded, so active engagement of the heritage sector (both academic and commercial) in their development is crucial. Work in that direction is promoted by BIM4Heritage (see [section 6.2.2](#)), academia, professional organisations and other focus groups (see [section 6](#)).

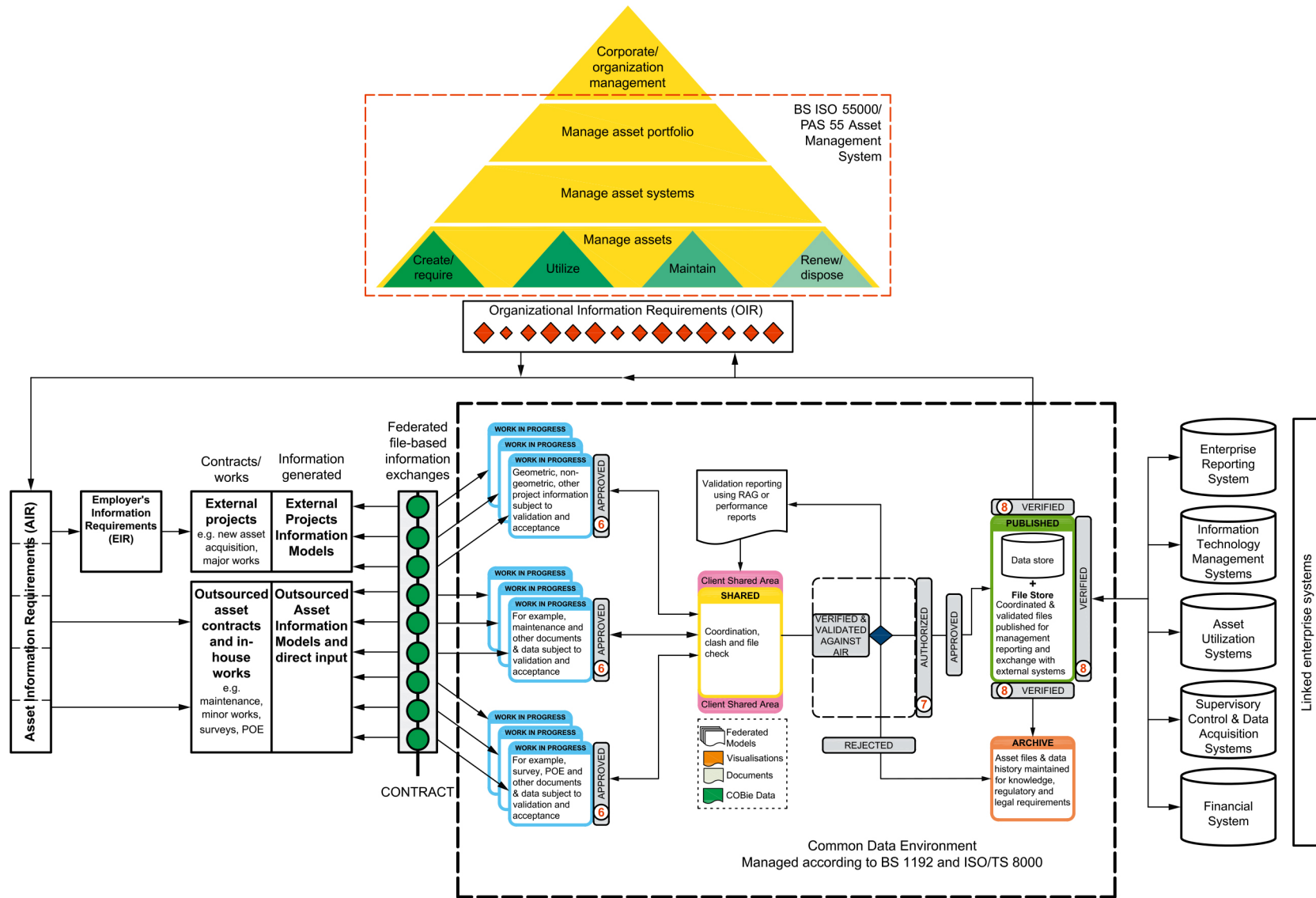

Figure 10  
 Ensuring data and information governance and assurance: a summary of the processes described in PAS 1192-3:2014 (BSI 2014b).

# 3 Managing BIM Data

BIM and collaborative working processes offer considerable benefits for construction and asset management, with similar potential for the heritage sector. Successful implementation, especially in large or complex projects, must be based on a robust IT infrastructure, well-thought-out workflows governed by standards and protocols, and (where appropriate) a sustainable strategy for long-term data management.

## 3.1 BIM infrastructure

BIM processes rely on appropriate IT infrastructure in terms of software, hardware and networks, which is informed by organisational and specific project requirements.

### 3.1.1 Software

It has often been stated that BIM is not about software, but rather a process for collaborative information production. However, BIM depends absolutely on software for producing, managing, exchanging, using and archiving information. It is unlikely that one BIM software tool can cover every project requirement. To overcome limitations and exploit the advantages or strengths of different digital tools, a digital ecology consisting of many interconnected BIM softwares can be used. The choice of BIM software is determined by a number of factors, including price, licensing options, software capabilities and interoperability requirements.

**Note:** There are currently several commercial BIM software providers, covering a range of prices and capabilities (authoring and coordination), available as part of software suites or as standalone products. Such applications include Allplan (Nemetschek), ARCHICAD (Nemetschek/Graphisoft), Revit® (Autodesk®), Navisworks (Autodesk®), Digital Project (Gehry Technologies), Solibri (Nemetschek), Vectorworks® (Nemetschek), MicroStation (Bentley®) and AECOsim (Bentley®).

Interoperability issues should be tested and resolved before the beginning of the project. Software versions are also important, as many BIM authoring softwares are not backwards-compatible, ie files created with one version of the software cannot be opened with earlier versions.

Different editions of the same software platform are sometimes available as lightweight or entry-level products. These tools may only offer some of the capabilities of the full version, but at a significantly lower price. Care should be taken to determine whether any limitations in modelling tools or other capabilities (eg integration of point cloud data) will render such products unsuitable for Historic BIM applications.

A number of plug-ins and additional tools are available to cover a range of applications, such as automatic geometry extraction (for scan-to-BIM workflows), clash detection, project management, visualisation, interfacing with other systems, and others. These may be available as free or paid-for add-ons to BIM software (usually available through the BIM software providers) or as standalone applications (desktop or cloud-based). Cloud-based applications and services are becoming increasingly more popular.

Some BIM software manufacturers provide free standalone or cloud-based viewers that allow clients and end-users simply to view and annotate the models. Depending on the software used to develop the model, these tools should be available on the manufacturer's website.

**Note:** Examples of free BIM viewers include Navisworks® Freedom (Autodesk®), BIMx (Graphisoft®) and Solibri Model Viewer (Nemetschek); a more extensive list is available on the BIM Task Group website (see [section 6.2.3](#))

Portable devices (such as tablets and smartphones) can be used for field BIM applications during site visits and client consultation. A range of useful mobile BIM apps (for viewing and annotation of models) is currently available and it is anticipated that their adoption will become more widespread.

### 3.1.2 Licensing

Acquiring BIM software often involves a significant upfront investment, depending on the number of licences and licensing model (perpetual or subscription). Depending on the applications, projects might require additional software or plug-ins, for example scan-to-BIM solutions, with additional costs.

Different licensing options may be available, depending on the software providers. More providers are shifting from perpetual licences to subscription models, which offer access to software on a pay-as-you-go basis. This can allow more professionals to access mid-range to high-end software at a more affordable rate by spreading the cost over time, and can be more flexible in terms of serving varying workloads.

Open-source BIM is an area of growing interest for software developers and designers alike, who are looking at the development of non-proprietary BIM software. There are some promising examples based on the IFC standard, but currently no reliable, all-round solution for building projects. It is expected that, as BIM adoption grows, more interest will be created for free, open-source tools.

**Note:** eXtensible Building Information Modelling (xBIM) is a free, open-source, software development toolkit that allows developers to create bespoke IFC-based applications, such as standalone software or add-ons for commercial BIM tools (see [section 6.4.4](#)). It is expected that, as BIM adoption grows, more interest will be created for free, open-source tools.

### 3.1.3 Data formats

BIM authoring software saves model files in various proprietary formats, such as RVT (Revit), PLN (ARCHICAD) and DGN (AECOSim Building Designer). In some cases these can be supported by other software, for example if they form part of a software suite, but interoperability relies mostly on non-proprietary data-exchange formats. IFC is the open-exchange standard for BIM and supported by most BIM software.

Integration of various datasets into BIM (point cloud, mesh, image, CAD) is based on exchange formats, such as ASCII (for point cloud data), TIFF and JPEG (raster images), DXF and DWG (CAD drawings) and OBJ (mesh models). Supported formats can vary depending on the choice of BIM software. Data-exchange schemas are required for information-exchange processes at BIM Level 2, such as COBie, which can be used (viewed, edited) in a neutral spreadsheet form.

### 3.1.4 CDE

A CDE provides the framework used to support interdisciplinary collaboration through BIM. It specifies a single source of information for the project, used to collect, manage and disseminate project information through strictly controlled processes. A protocol of use must be in place and strictly adhered to by all members of the project team to ensure information consistency and quality. The CDE may be a shared network location, project extranet or an electronic document management system (EDMS).

**Note:** A CDE not only applies to BIM projects, but is necessary for BIM Level 1 and higher.

**Note:** BS 1192:2007 (BSI 2007) defines the use of a CDE for information production in the AEC industry (Figure 11), while PAS 1192 parts 2 and 3 (BSI 2013b, 2014b) explain further the application of a CDE for BIM projects during the capital and operational stages of assets, respectively. These documents do not specifically refer to heritage projects but their recommendations on the use of collaborative working environments should be applicable in most scenarios.

**Note:** Naming conventions are crucial for information management processes, especially in the absence of a data management system able to support metadata. The application of a file-naming convention allows users to search easily for and retrieve relevant files. The adoption of a file-naming system is good practice and not only applicable to BIM projects.

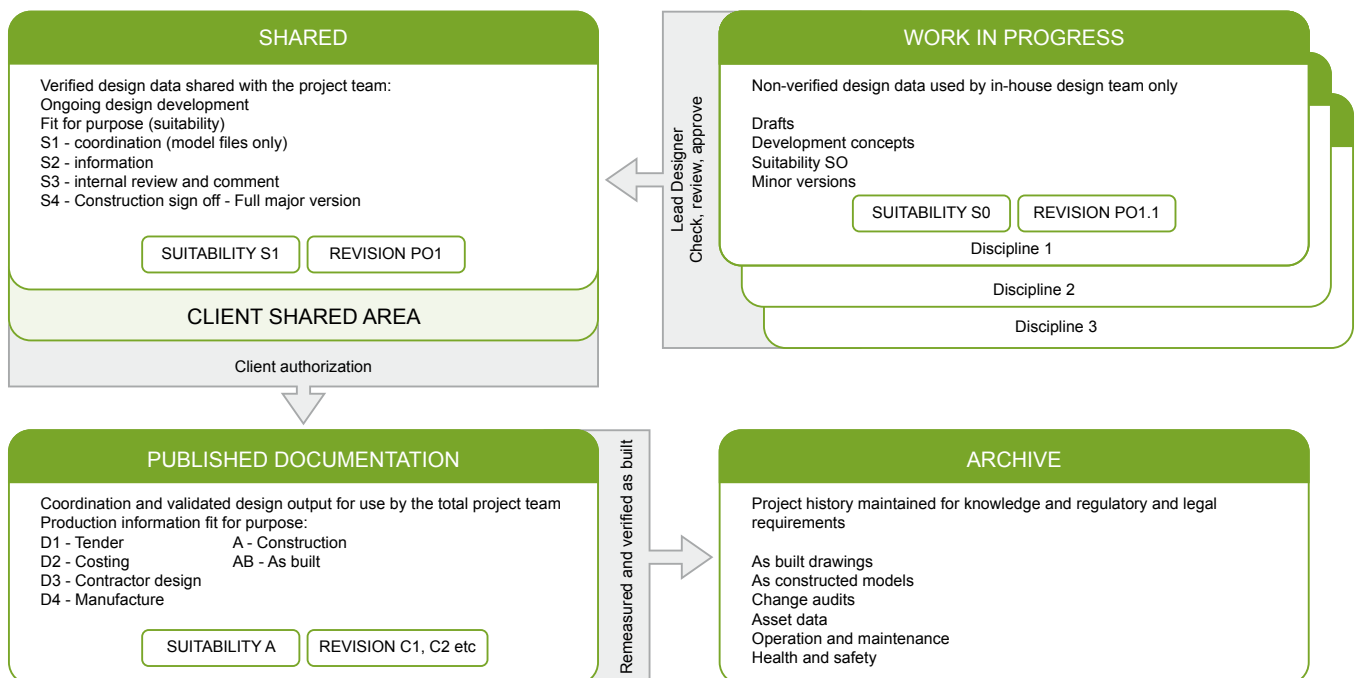

**Figure 11**  
An outline of common data environment (CDE) principles.

### 3.1.5 Hardware and networks

BIM file sizes will vary significantly between projects, depending on asset size and information requirements. Generally, BIM software runs on desktop computers with high specifications for random-access memory (RAM) and processing speed, although high-specification portable computers can be used. The hardware specifications published by the software providers should be consulted regarding the specific version of the software and any additional requirements (such as the need to process or view geospatial datasets).

Long-term use of BIM software will also create a need for periodic hardware updates, as the requirements (in terms of processing speed, RAM, storage and connection speed) will only continue to grow. Over-specifying hardware can provide better value for money in the long run, by anticipating additional requirements for future software releases.

### 3.1.6 Networks

Networks are essential for collaborative working, either through a local network or in the cloud. Accessibility and security issues regarding the use of the CDE should be properly managed with support from IT professionals.

As the availability and adoption of cloud-based BIM applications grow, connection speed requirements increase. High bandwidths and appropriate network configurations are essential for collaboration, especially when the project team is dispersed geographically.

**Note:** Maximum file sizes for BIM are determined by a combination of factors, such as software, hardware, CDE and network capabilities (see [Case Studies 1–8](#)).

## 3.2 Standards and protocols

The use of BIM project standards is an essential step in ensuring consistency and quality control, especially in the case of collaborative working processes. Best-practice BIM requires all members of the project team to follow pre-agreed procedures. These can be conceived as a suite of specifications for naming conventions, spatial coordination, modelling, CAD standards, templates, metadata and information exchange processes. Standardisation requires strict discipline by all members of the team, and is necessary to eliminate ambiguity in the information production process.

The latest version of the AEC (UK) BIM Technology Protocol (AEC (UK) 2015), which has been aligned with the recommendations of PAS 1192-2:2013 (BSI 2013b), provides comprehensive guidance on developing BIM standard procedures. Supplementary documents have also been released, specifically for application with the most widely used BIM software (see [section 6.1.1](#)).

Custom content creation is usually a requirement for Historic BIM projects, as built-in or online object libraries tend to include mainly new-build rather than historic or traditional building components. Some content can be appropriated from such sources and used in the project; however, the inclusion of BIM objects from various sources (with different creators, purpose and context) can be problematic for information consistency.

Adopting a BIM object standard is strongly advised, which can be used (a) for creating any new project-specific content and (b) to validate content appropriated from other sources. Only content that has been checked for compliance with the adopted project standard should be allowed in the project BIM object library and subsequently in any model(s).



**Note:** The NBS Object Standard defines requirements for the information, geometry, behaviour and presentation of BIM objects, providing a consistent approach for all BIM content and ensuring the quality of information produced. The NBS Object Standard relates to COBie and IFC (see [section 6.1.4](#)). It is available to download for free from the [NBS website](#).

**Note:** Consistent parameter definition is important for data querying and information extraction. The NBS Object Standard includes a number of common parameter definitions, but also provides a convention for additional parameters that are useful for heritage projects. Parameter definitions can form part of the agreed project standard procedures.

**Note:** Objects from the project BIM object library can then be useful for other projects in the future. With that in mind, any potentially useful content can be copied from the project library to a central BIM resources library. When a new project starts, content from the central library can be appropriated, checked against the adopted project-specific standard and copied to the relevant project library.

### 3.3 Dealing with the data

It has been repeatedly suggested by others that the long-term benefits of BIM are realised in the operational stage, when the BIM is used to manage all the information related to the operation and maintenance of the asset. For that to happen, the AIM must be continuously updated to reflect changes in the physical asset(s). This implies a process of model maintenance or ‘curation’ of the information model. A programme should be in place for checking, validating and updating the model according to ‘trigger’ events, ie changes in the physical asset. It follows that BIM used for asset management cannot be a static object. Superseded versions of the asset model should be archived according to standards, as they provide an audit trail and document the state of the asset at different points in its life cycle.

Long-term model curation has implications in terms of resources, requiring either inhouse skills or external contracts to be in place. This can be linked to existing processes for asset management and should be assessed on a case-by-case basis.

There is ongoing debate about long-term archiving solutions for BIM. As stated, these do not refer to the current AIM used for facilities management FM and asset management applications, but rather the series of superseded ‘snapshot-in-time’ models. Discussions revolve around appropriate archival data formats (such as the use of IFC), metadata and IT requirements to ensure long-term maintenance of relevant data. Guidance on digital archiving to enable decision-making for heritage, as well as for heritage interpretation and presentation, is available from the [Archaeology Data Service](#) (ADS) (see [section 6.2.1](#)).



BIM training and skills development are an important part of BIM implementation. Training requirements will not be the same for all members of an organisation or project team, depending on their role and existing BIM skills. The role of self- or peer-to-peer training and skills development should not be underestimated.

Two areas of training can be isolated:

- BIM software, model and content creation
- BIM processes and management.

For heritage applications, a good understanding of the software and possibly advanced modelling skills is a requirement. Knowledge of project standards and correct procedures is also important, especially for collaborative BIM.

BIM training is now widely available in the UK through a number of providers and consultants. Software providers can provide training resources and some also publish lists of accredited training centres on their websites. Different training options may be available, such as external courses, inhouse seminars or E-learning services.

Timing is of the utmost importance. Most practitioners agree that training activities should be scheduled at the beginning or made available during the course of a project, responding to immediate needs for specific BIM skills. This is not always easy to achieve, but it ensures that new skills can be utilised immediately and are less likely to be forgotten. A programme of continued skills development should be considered.

**Note:** Skill assessment services can be beneficial for identifying skill gaps within an organisation or used to test skill levels across a project team.

**Note:** Accreditation schemes exist for certifying BIM skills, such as the Royal Institute of Chartered Surveyors (RICS) BIM manager certification (aimed at chartered surveyors) (see [section 6.2.11](#)) and the BRE BIM certification schemes (for individuals or organisations).

# 4 Commissioning BIM

This section provides useful information if you are interested in procuring BIM work. It is primarily applicable to organisations and individuals involved in heritage conservation projects and asset management of historic buildings and sites.

Asking for 'BIM' or 'full BIM' on a project is simply not enough without further defining what that requirement involves. Professionals and clients with BIM experience (both in the new-build and heritage sectors) highlight lack of clarity regarding information requirements as a significant obstacle for successful BIM delivery.

Commissioning BIM services requires both client and supplier input and communication. It is a two-way process: (a) the clients must clearly define their information requirements, as part of the overall employer requirements for the project, and (b) suppliers must develop a BIM strategy for information delivery, in response to the stated employer requirements.

UK guidance in the form of the PAS 1192 series (eg BSI 2013b, 2014b; see also [section 6.1.2](#)) provides detailed recommendations for efficient information delivery in construction projects. The proposed process starts with the definition of the employer's information requirements (EIR), towards which the supplier responds with a BIM execution plan (BEP), which in simple terms defines the strategy for project delivery using BIM. The scope, purpose and content of the documents used to support information management processes are detailed in PAS 1192-2:2013 (for the capital phase; BSI 2013b) and further developed in PAS 1192-3:2014 (for the operational stage; BSI 2014b).

**Note:** Advice on producing EIRs in the form of a [template document](#) is available on the BIM Task Group website (see [section 6.2.3](#)). A [template BEP](#) is available to download from the Construction Project Information Committee (CPIC) website (see [section 6.2.7](#)). These model documents are only advisory and therefore should be adapted according to project needs.

**Note:** It is outside the scope of this document to discuss in detail how PAS 1192 (BSI 2013b, 2014b) recommendations can be applied to historic assets. However, these recommendations provide a robust framework to support collaborative information production for AEC projects across different sectors. The appropriate adoption and adaptation of PAS 1192 specifications in heritage projects will help foster interdisciplinary collaboration and the alignment of the heritage sector with the rest of the AEC industry in terms of digital working capabilities.

## 4.1 Knowing what you want

Knowing what you want and having a clear vision of what you are using BIM for is the first and fundamental step when commissioning BIM work. It is the client's duty to set the scope and purpose of the work and define the information requirements. Information requirements should be determined on a case-by-case basis, taking into account the overall organisational requirements and project parameters.

Within the standard BIM approach, client requirements in terms of BIM services can take the form of an EIR or asset information requirement (AIR) document (as defined in PAS 1192-2:2013 and 1192-3:2014, respectively; BSI 2013b, 2014b). These should specify requirements for levels of detail, coordination and clash detection, model management, naming conventions, use of coordinate systems, software and file formats, security issues and information restrictions, information exchange processes (including alignment with programme stages and deliverables), as well as the standards and protocols that should be applied in the project. These can be summarised into three areas: technical, management and commercial.

**Note:** BS 7913:2013 (BSI 2013a) states that the immediate objective of building conservation is to secure the protection of built heritage, in the long-term interest of society. Issues relating to building conservation are often complex and interwoven. The conservation of historic buildings requires judgement based on an understanding of principles informed by experience and knowledge that can be exercised when decisions are made.

BIM for existing/historic assets requires a significant initial input of information. Client requirements in Historic BIM projects should define carefully the scope and deliverables of data-acquisition activities, including metric surveys, site investigations, desk-based assessments and management of legacy information. For the procurement of AIM, AIRs

should cover how data and information will be captured and fed into the model (according to PAS 1192-3:2014; BSI 2014b).

**Note:** Section 8 of Historic England's metric survey specifications (Andrews *et al* 2015) defines key requirements for the procurement of a BIM-ready dataset (LOD, modelling tolerance, data formats and deliverables).

Requirements in terms of geospatial datasets and other survey deliverables can be expressed as survey briefs in the form of a survey specification. Andrews *et al* (2015) provides guidance and template specifications for a range of survey methods, such as image-based, measured survey and laser scanning. Survey specifications of this type can form part of the overall AIRs.

**Note:** EIRs are used in the case of capital projects, as defined in PAS 1192-2:2013 (BSI 2013b). AIRs are specific to the asset and may not be related to any construction/capital project. AIRs can inform an EIR in the case of major works. Both are informed by overarching organisational information requirements (OIR).

**Note:** Several commercial companies produce their own BIM specifications, which are often tailored for scan-to-BIM applications. These can help clients define their requirements for the procurement of BIM-ready datasets, but should always be considered in the context of UK BIM standards and specifications to ensure compliance with specific BIM maturity levels.

## 4.2 Developing a BIM strategy

According to UK BIM standards (specifically PAS 1192-2:2013; BSI 2013b), in response to client requirements, information suppliers are expected to deliver a BIM strategy for information delivery, aligned with the wider project deliverables. This is defined as the BEP. A BEP responding to employer requirements should be produced before the start of the project (after the contract is awarded), communicated to and agreed on by the entire project team. The BEP and associated documents form the blueprint for delivering a project using BIM.

A BEP should explain the information management approach, outlining roles and responsibilities and setting project milestones in terms of information delivery aligned with the overall project programme. The contents of the BEP are described in detail in PAS 1192-2:2013 (BSI 2013b, section 7.2).

**Note:** The contents of the BEP as described in PAS 1192-2:2013 will have to be adapted to suit the particular requirements of Historic BIM, particularly in relation to documentation and acquiring as-existing datasets.

For Historic BIM especially, it is essential for the BIM strategy (or BEP) to detail the survey strategy (if additional surveys are necessary), outlining the selected approach towards metric data acquisition and use of existing legacy data, including the validation process. The project standard method and procedures (see [section 3.2](#)) and IT solutions should also be included.

The clear definition of a BIM strategy should not be considered as another contractual obligation or simply a 'tick box'. Developing a plan for information delivery using BIM is good professional practice, not only for construction or asset management but also for heritage research and investigation projects. BIM processes can be complex even within small projects, especially when they involve collaborative working. Therefore, any BIM project regardless of size or

scope would benefit from a clear articulation of requirements and subsequent development of BIM delivery strategy.

Pilot projects and case studies in particular can benefit from a clearly defined BIM strategy. After the end of the project (or after significant project milestones), the effectiveness of the delivery method can be assessed by comparing the real and expected outcomes, as stated in the BEP and AIR/EIR documents.

## 4.3 Assessing supplier capability

It is important for the client, when commissioning BIM work, to have a level of confidence regarding the capability of the supplier to deliver the project successfully using BIM, in the manner that was requested. Existing BIM guidance suggests the use of supplier BIM assessment forms, which can cover a number of topics, such as general BIM knowledge and understanding, application of standards, staff resources, training and relevant experience. This type of assessment is typically carried out prior to awarding a contract. However, assessing BIM capability within a project team or an organisation, irrespective of any running project/contract, may also be a helpful exercise for BIM planning at an organisational level.

**Note:** There are several resources available online, such as template documents for supplier capability assessment (see [section 6.2.7](#)), cloud-based paid-for services for BIM skills assessment, and free online assessment tools focusing on standards knowledge and implementation, such as the BIM Compass available on the Scottish Futures Trust BIM Portal (see [section 6.2.12](#)).

## 4.4 Legalities

The introduction of collaborative BIM practices alters the working relationships between the different parties involved in construction projects (employer, consultants, contractor, subcontractors, etc). This has significant legal implications, as existing contracts do not cover the various relationships affected by BIM implementation.

The current solution is to incorporate the CIC BIM protocol (Beale and Co 2013) as a set of amendments to existing contract forms. In collaborative BIM, models consist of contributions made by several parties. A BIM protocol ensures that all parties retain intellectual property rights (IPR) on their contributions, but provide a licence

to all other members of the project team to access and use that information. The question of how this emerging arrangement can be future-proofed for conservation projects, where the intended life cycle of the asset can be expected to extend ‘for centuries’ into the future (where ownership and project teams will regularly change), remains unaddressed.

**Note:** The subject of IPR and professional liability on BIM projects is complex. Some guidance is available online from the BIM Task Group on the use of the CIC BIM protocol and professional indemnity insurance, and the NBS website also provides guidance on legal issues surrounding BIM implementation (see [sections 6.1.4](#) and [6.2.3](#)).

# 5 Helping You Decide

This section provides answers to a series of questions that will be relevant to AECO and heritage professionals, historic asset managers and clients who may be considering BIM adoption for projects involving historic assets.

## 5.1 Are you required to procure/deliver a project using BIM?

At the moment, the UK government mandate for BIM Level 2 adoption applies to all centrally procured public projects regardless of project value, as explained in section 1.4. Different requirements are in place for public projects in Scotland and Northern Ireland. The government mandate makes no distinction between new-build and existing assets, therefore it is applicable to heritage conservation projects. BIM adoption in the private sector is not in any way mandatory, but may be driven by client requirements or the project team (usually the lead designer or contractor).

**Note:** More information on the government mandates can be found in [sections 6.1.2](#) and [6.2.12](#).

## 5.2 How could you benefit from adopting BIM on a heritage project?

The adoption of BIM in the new-build construction sector is driven by significant gains in terms of efficiency and cost savings during capital and operational stages. Similar benefits can be expected in construction projects on historic assets with additional advantages in terms of spatial coordination (through integration of geospatial datasets and clash detection) and conservation planning (through improved visualisation, analysis and options appraisal).

BIM can be a valuable tool for historic asset management. However, without the benefit of a pre-existing BIM dataset (possibly in the form of a PIM), the creation of an AIM requires a significant investment, especially if the standards expected for new-build projects (LOD, tolerances) are to be observed. In that case, a cost-effective approach may involve specification of the minimum amount of graphical data and information, measurement and modelling that would be sufficient to support maintenance and asset management activities. BIM offers a robust information management framework that can be highly beneficial for heritage research and investigation; some examples are provided in Osello and Rinaudo (2016).

**Note:** The Scottish Futures Trust has developed an online ROI calculator, which assesses the benefits and level of return that the adoption of BIM Level 2 will have on a construction project (see [section 6.2.12](#)). The assessment is both qualitative and quantitative and based on specific project information. The ROI calculator has been developed to support public sector procurement in Scotland, but can be useful in other construction projects.

### 5.3 Who will be responsible for maintaining the AIM?

This is an important question for historic asset owners and asset managers, as the AIM may have been commissioned externally, produced inhouse, or be the result of information handover from a capital project. In order to use the AIM as an effective asset management tool, it is imperative that it is maintained, checked and updated to reflect changes in the physical asset. This process can be undertaken inhouse by appointing a model manager, who will be responsible for reviewing, validating and updating the model as necessary. Alternatively, this service can be procured via an external contract.

### 5.4 Can you do this yourself?

Delivering a project using BIM tools and processes, especially when it involves complex or significant historic assets, can be a daunting prospect. You need to consider the potential benefits of BIM, for example by analysing the ROI, before making a decision. BIM adoption does not necessarily need to start at BIM Level 2, unless required by the government mandate or other factors. A different BIM methodology, for example non-collaborative, may be more appropriate for some applications.

A BIM project starts with the process of clearly defining information requirements, towards which a BIM strategy for information delivery can be developed. This approach (articulation of requirements, definition of BIM methodology) is recommended, not only for the procurement of BIM services, but for any BIM project including heritage research.

There is a wealth of information, standards and recommendations available online to help guide you through the process, although these are rarely specific to heritage projects (see [section 6](#)). Familiarisation with BIM standards, template documents and at least a basic knowledge of BIM technology is recommended, prior to the start of a project. These should be considered in conjunction with an understanding of current conservation standards, criteria, principles and practice.

Embarking on a pilot project is a major step towards BIM adoption within an organisation (from the perspective of both BIM client and BIM supplier). A representative project of manageable size and scope can be used to test software and skills, develop inhouse BIM protocols and standard procedures, develop information requirements (for clients) and inform the organisational strategy in terms of BIM implementation. A post-project review should be carried out to ensure that the experience gained through a pilot project informs future practice.

The adoption of BIM and collaborative working in the heritage sector (both for construction and asset management) requires organisations and individuals to embrace change and accept that traditional roles and practice models may need to be adapted to deliver projects successfully using BIM. At the same time, BIM offers an opportunity for modernisation and increased efficiency in the sector, by incorporating digital technologies appropriately within heritage and conservation practice.



# Case Study 1

## A1 Leeming to Barton Project: Fort Bridge

### Introduction

The A1 Leeming to Barton (A1L2B) motorway upgrade is a large linear scheme to upgrade a section of the A1 in North Yorkshire to motorway standard. The work has involved widening sections of existing road as well as the construction of new sections of motorway, local access roads and six new bridges.

AECOM and SWECO, as designers, have been providing archaeological advice and guidance to the Carillion Morgan–Sindall Joint Venture throughout the lifespan of the project, as the road passes through a sensitive archaeological landscape. Known archaeological sites include the Roman settlements of Bainesse and Cataractonium, both of which are scheduled monuments, while previously unrecorded sites include an Iron Age settlement, an Iron Age burial ground and a new Roman settlement at Scotch Corner.

Of the previously identified sites, Cataractonium represented one of the main engineering challenges as the Roman fort and town is located at a pinch point where the A1 crosses the River Swale. Engineering works in this area included replacing a bridge, known as Fort Bridge, which carries the A6136 across the A1 near Thornbrough Farm and Catterick Racecourse. This case study focuses on the Fort Bridge area.

### Why was BIM selected?

In early 2016 extensive archaeological remains were encountered at Fort Bridge, an area located in the south-west corner of Cataractonium Roman town. Photographs surviving from the A1 road construction in the late 1950s indicated that archaeological deposits adjacent to the road corridor had been severely damaged, and as a result no significant remains were predicted. However, work in 2016 revealed that remains of the Roman town were well-preserved.



**Figure CS1.1**

An aerial view of the Fort Bridge area. Thornbrough Farm, located on the site of the Roman fort, can be seen in the bottom left corner. Archaeological excavations can be seen taking place near the yellow cabins and the racecourse.





**Figure CS1.2**

A general view of the excavations taking place at Fort Bridge.

This raised the issue of impact resulting from utilities diversion and drainage required as part of the road scheme. As Building Information Modelling (BIM) had previously been used on the project to aid with clash detection between elements such as utilities, drainage and structures, it was decided that BIM might be a suitable tool to assist in identifying potential impacts on archaeological deposits.

### **How was the project undertaken?**

As BIM had been widely used on the A1L2B project in a design capacity, a model already existed that contained the engineering details. When the decision was taken to try and model impacts on archaeology around Fort Bridge, the AECOM design team had to add archaeological data to the model. To do this, heights were taken on the upper levels of archaeology that were visible where excavations were taking place at Fort Bridge. In addition, a number of trial holes were excavated along the edge of the A6136, in the vicinity of the proposed utilities and drainage works, in an attempt to identify the upper levels of archaeology across a wider area, thus enabling a more accurate picture of underlying deposits to be extrapolated within the study site.

Once the archaeology layer had been added to the BIM product, the model was updated with designs for new diversions provided by the various utilities companies. This final model, therefore, allowed any potential impacts from the statutory diversions on archaeological deposits to be identified.

### **What was the deliverable output?**

The final BIM product allowed users without a background in engineering to see clearly where archaeological deposits could be damaged or lost as a result of the construction of new drainage and utilities diversions.

This enabled mitigation measures to be developed in advance of site works starting, and also reduced the risk of time delays to the construction programme. This included identifying where an archaeological watching brief would be appropriate, and which areas warranted full excavation, all of which was done in conjunction with Historic England. The use of BIM also aided the design process, as the early detection of archaeological impacts allowed, in some situations, the design team to reconfigure works to avoid archaeological deposits.

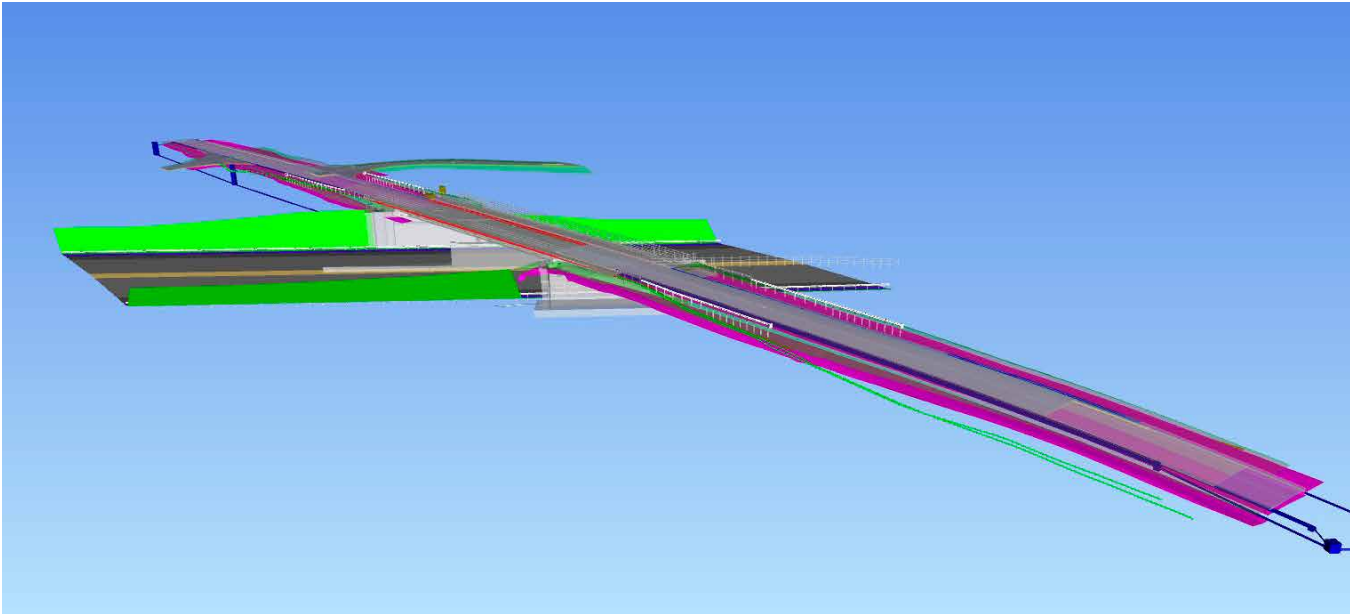

**Figure CS1.3**

A screen capture of the BIM product showing the Fort Bridge structure along with the new utilities and the top of archaeology in purple.

### **What problems were encountered?**

Although the final BIM output was a success, allowing potential impacts on the archaeology to be identified, there were difficulties with the collation of data. As with any project involving numerous stakeholders and a rapidly evolving design, it was difficult to achieve a final fixed design that could be uploaded into the BIM product. Further delays also resulted from stakeholders having to redesign their elements when clashes were detected, or when impacts on archaeology were detected.

The BIM product is only as good as the data being uploaded. In the initial model, the upper level of archaeology was taken from the excavations to the west, and it was assumed that it continued at the same level across the study area. This was later improved on with the excavation of additional trial holes to obtain a more accurate reflection of the archaeological deposits.

Finally, the software used was still relatively new and uncommon, which meant few people were trained in its operation. This, at times, had the potential to cause delays in updating the model with new designs. It meant that it could be

difficult to find an individual available to ‘drive’ the model; models within a BIM environment cannot currently be emailed between individuals for easy sharing, although images produced via screen capture can be shared. These are, however, issues that should be easily remedied as the software becomes more readily available and is used by a wider audience.

### **How was the BIM data used within the project?**

The end-product was used by the A1L2B project team to identify the potential impacts on archaeological deposits and assist with redesign where possible. A final model was then used to show key stakeholders, such as Historic England, the potential impacts on archaeology resulting from utilities and drainage. This in turn allowed a suitable mitigation strategy to be developed.

It has not been possible to quantify accurately the time or cost of creating the BIM product as the final model used an existing BIM package created for the construction of the road, with the required archaeological data added. The final dataset, which focused on Fort Bridge, created a file of 8MB, which provides a reasonably manageable data set.

# Case Study 2

## Edinburgh Waverley Railway Station

### Introduction

Because of its experience working with Building Information Modelling (BIM) in the heritage sector, AHR was approached to survey and provide a three-dimensional (3D) model of the listed ticket office and adjacent staff areas at Edinburgh Waverley Station, Edinburgh, Lothian, Scotland. The survey encompassed two floors and was to include the roof and concourse areas.

### Why was BIM selected?

The driving forces behind the decision to follow a BIM workflow were cost and timescale. BIM has a proven track record of reducing overall capital cost through efficiency, and minimising the timescale through a higher level of communication between all team members.

### How was the project undertaken?

AHR has found that it is essential to hold a BIM execution meeting (BEM) prior to any works being carried out, and to create a BIM execution plan (BEP) at that stage. The BEP outlines everything from the responsibilities of each team member to the timings of data drops and levels of deliverables. This plan is agreed by all parties and forms the basis of all the work to be carried out. The BEP, a common data environment (CDE) that provides the framework used to support interdisciplinary collaboration, and the 3D model are the most important items of any BIM project.

The survey was carried out using a mixture of traditional and laser scanning technology, to ensure that the project delivered an auditable accuracy. At the start of the survey, a primary survey control was established to form the backbone of all the subsequent work. The primary control comprised a closed loop traverse with a minimum closing tolerance of 1:30 000, to ensure secondary control would yield the intended results. Part of the control was positioned outside the station to allow the survey to be extended at a later date if required.

It was decided that because of the nature of the project, the spaces involved and the short time periods available, a FARO® laser scanner would be used to capture the 3D data. In order to deliver the level of accuracy stated in the BEP, all registration targets were coordinated using the total station and target positions referenced directly to the primary control ring. Time pressure meant that some flexibility had to be allowed for this process to occur. To facilitate this, registration spheres were used in conjunction with coordinated targets to achieve the best results. Two scan teams were on-site for a period 1.5 weeks to capture all the laser scan data and establish the control.

The scan data then had to be registered, which was carried out by the lead surveyor of each team. The lead surveyors are allocated this task because they have the best knowledge of the site and know about any issues that arose during the data capture.





**Figure CS2.1**  
Sectional view through the colourised laser scan point cloud of the listed ticket hall.

The final process is a comparison between the known coordinated registration points positioned with the total station and the same points as they appear in the point cloud, to make sure that the integrity of the data has remained intact. Overall the indexed point cloud was 80GB in size, which is not unmanageable.

### What was the deliverable output?

An as-built 3D Revit® (Autodesk®) model, BIM-ready, was to be the overall main deliverable. This was to be supplemented with a registered colour point cloud and a SCENE WebShare (FARO®) that AHR would host on its server. The model itself was fairly basic and straightforward, as most railway stations are, apart from the listed ticket hall. This contained a number of items of interest containing complex geometry, not least of which was an intricate domed skylight that dominated the area.

In total, three modellers were allocated to the project for 1.5 weeks, with a further 2 days to bring the various components together and audit the complete model.

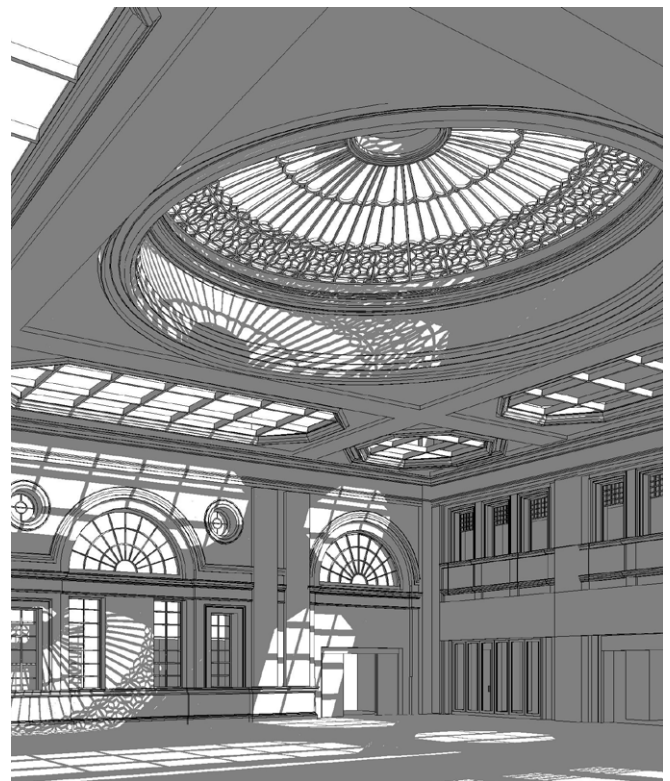

**Figure CS2.2**  
BIM-ready model of the listed ticket hall.

### What problems were encountered?

The main issue encountered was not with the actual data capture, even though the surveying could only take place during strictly allocated time slots, but the modelling itself. Revit is an extremely powerful piece of software and lends itself to the BIM workflow perfectly. However, using it to model irregular objects, as encountered in most heritage projects, highlights its shortfalls. To overcome this problem, other third-party software, designed to create complex geometry or meshes, was used. These were then converted to a format Revit could understand. Such files tend to be large and inflate the model size, so a compromise has to be made between the level of detail shown and the usability of the model. Overall, the size was kept down to 50MB.

Many of the problems with this type of project arise from the client's expectations and the reality of both the visual appearance of the model and the data contained within it. This is why the BEP is invaluable, because it defines the parameters before the surveyors have arrived and outlines the planned use of the information at every stage of the project.

Another issue can be the storage of the scan data. As a regular user and creator of scan data, AHR understands its storage space needs. Unfortunately the client did not. As a solution, AHR agreed to hold the raw data on its system for a period of 12 years and supplied the registered cloud on a portable hard drive to the client. This solved the issue of server space and provided a disaster recovery strategy.

### How was the BIM data used within the project?

From a surveyor's perspective, the BIM data was in general minimal. The model comprised all the expected geometry parameters, along with the materials, but little else. The model had to be set up in such a way that a series of blank fields was created that can be populated with metadata in the future. The additional data can be anything from programming phasing of items for the re-fit, to manufacturer details and prices of components. If set up correctly, each discipline can add the required information as needed rather than the model being filled to capacity at the outset with redundant information. It is incredibly important that the items contained within the model serve a purpose. The user must be able to interact with, filter and schedule out any item contained in the model. Without this facility, the model is nothing more than an accurate 3D representation of the building and does not work within the ethos of BIM.

The intention for this study was to have all the prominent data along with the model housed in a single CDE. The CDE allowed a greater level of collaboration, the whole team having access to the most accurate current data, which in turn increased the project's efficiency in the context of constant pressure to cut costs and raise efficiency levels.

Heritage projects are not substantially different from any other project using BIM. All BIM projects require forward planning, models and data. The only difference is the extra layer of historic data collected for heritage projects. This specialist level of data allows more informed choices to be made by not just one or two people but the whole team through the use of the CDE.

# Case Study 3

## Woodseat Hall

### Introduction

Woodseat Hall is situated to the south-west of Rocester, Staffordshire. Built in 1767 as a home for the High Sheriff of Derbyshire, it was constructed by Thomas Bainbrigge. Following his death, the Hall became the subject of contest of many wills, which led to 40 years of instability for the asset and its subsequent decline. Further changes of ownership led to its eventual ruinous state. In 1986 the Hall was purchased by JCB.

The mansion was built in Georgian style with neoclassical ornamental features. Its strict symmetry is still recognisable on the remaining north and south wings. The main body of the building has, however, disappeared almost completely. Only a few bricks, sandstone plinths and an overgrown stair suggest where the main entrance used to be. The orangery attached to the south wing of the Hall has retained its original footprint and its north-facing solid brick wall. However, the south-facing glass façade and glass roof have both largely collapsed, and the timber window frames disintegrated. Only the lightweight iron beams reveal the ornate character this room once displayed. In November 2016, Bridgeway Consulting was appointed by JCB to carry out surveys to aid design works in the planning application process. The planning application made by Bamford Property Ltd/JCB proposed a complex redevelopment of the area, including restoration of the Hall and its conversion into a golf clubhouse.

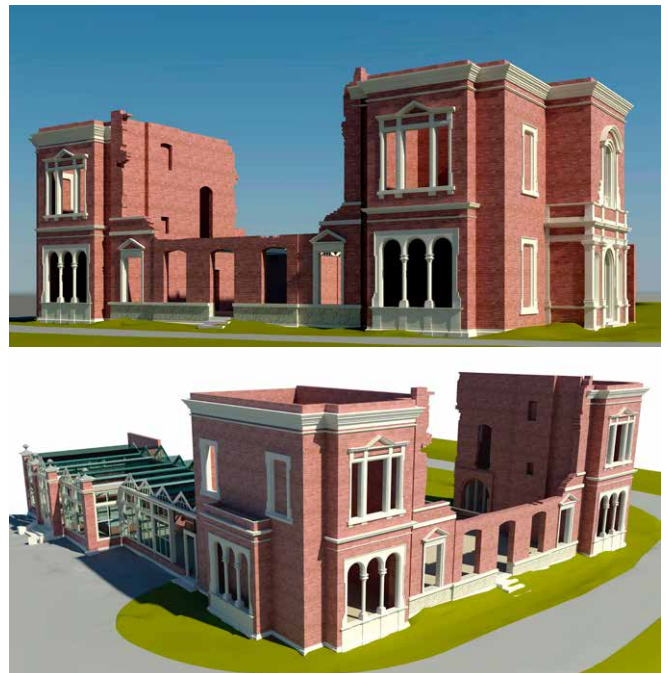
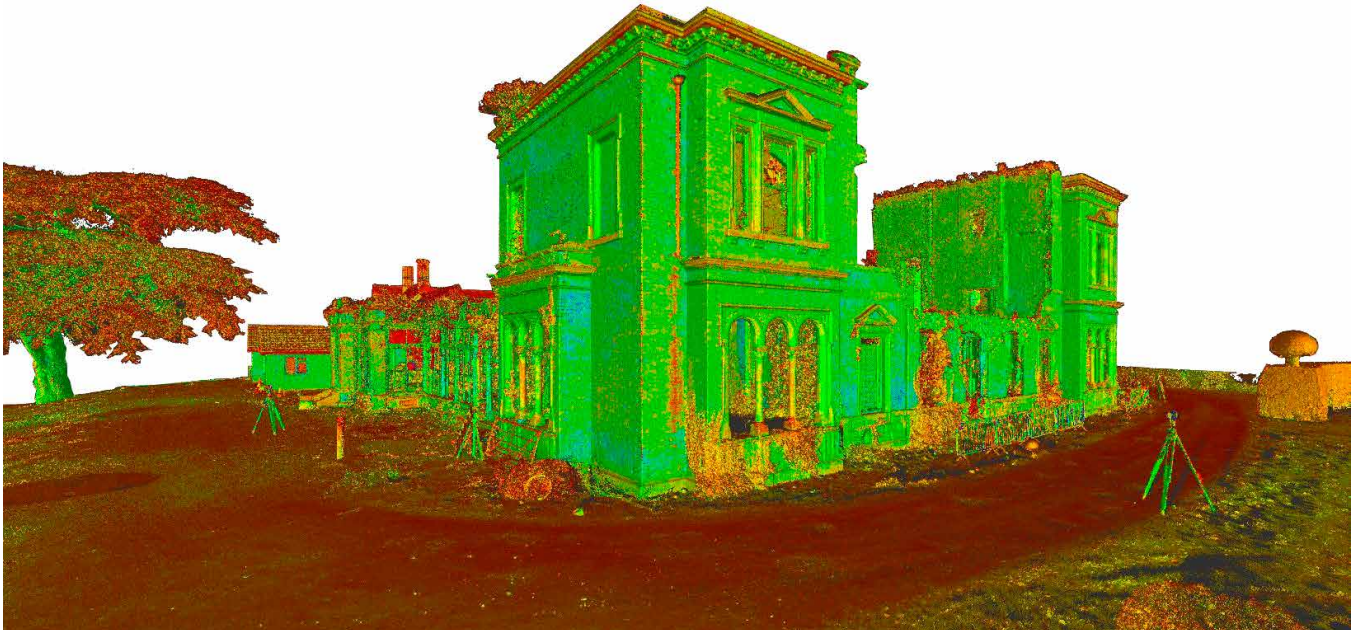

**Figure CS3.1**  
BIM-derived views of Woodseat Hall.

### How was the project undertaken?

Leica ScanStations P30 and C10 were used to capture the three-dimensional (3D) geometry of the building and surrounding area. A network of control points was installed and coordinated to the UK Ordnance Survey (OS) national grid using traverse methods and global positioning system (GPS) virtual reference stations (VRS). The 3D scans were registered in Leica Cyclone processing software, and the point cloud exported in the required PTS format.





**Figure CS3.2**  
Laser scan point cloud of the Hall.

Before the point cloud was imported into Revit® (Autodesk®), it was indexed and converted from PTS to RCS format. All modelling and graphical work was carried out within Revit 2015. The client was interested in capturing all the prominent architectural features as well as any structural defects that impacted on the external elevations. Access to the site was relatively unrestricted, enabling uninterrupted scanning and maximising data capture. Scanning also enabled unstable areas to be measured and detailed without risk to personnel. Using the Bridgeway 3D scanning methodology ensured high accuracy of the collected data, prompt processing and handover to the modelling team within 1 working day. Laser scanning was the chosen method because of the demand for a fast turnaround of the model and the complexity of the architectural features. Traditional survey methods would have significantly extended the time required for on-site work, and it would have been difficult to capture all the architectural features as accurately, given their inaccessibility.

### **Why was BIM selected and how was the BIM data used within the project?**

Building Information Modelling (BIM) was selected by the client to facilitate the planning application design works. Current conditions captured within a BIM environment were incorporated into the architect's model. In order to keep the size of the model file to a minimum, individual features were custom created as Revit families. This approach also ensured that all components were correctly named and logically organised within the model structure, and provided easy navigation. This stage of the project did not require parameters to be introduced to the model components, however the model's potential exceeded the limits given by its expected use. The whole life cycle of the asset could be captured in the model, eg current structural defects, material characteristics, up-to-date inspection reports, legacy information, photographs, sketches, drawings, future proposals and meeting minutes can be linked to specific features and areas. This could contribute significantly to an efficient collaboration between the owner of the asset and all other parties involved. One shared virtual data environment would also ensure that all available documentation was regularly updated and maintained, and duplication avoided.



### What problems were encountered?

For the purposes of the planning application, it was essential to capture the full extent of all the external elevations, including the top edges of the walls. The positions of scanning stations were carefully assessed and selected to ensure minimal shadowing in the point cloud, and maximum capture of contours. The proximity of a large lake combined with low temperature and rainfall resulted in difficult weather conditions, including dense fog and low visibility. This impacted on VRS locations. Distances between individual stations had to be optimised to ensure that laser rays would penetrate the dense fog. During the modelling phase, no problems were encountered. The size of the point cloud was 3.6GB and the size of the model itself was just 24MB. This allowed easy navigation and speedy delivery processes.

### What was the deliverable output?

Bridgeway Consulting Ltd was contracted to supply:

- a 3D laser scan in the format of a PTS point cloud
- a 3D model in RVT format (the software specified was Revit 2015)
- external elevations in DWG and PDF formats.

The entire process, beginning with data collection and followed by its processing to the subsequent 3D modelling and graphical presentation, took 4.5 days: 1 day dedicated to survey works on site, half a day of data processing in the office and 3 days of modelling. As specified by the client, all architectural and structural features captured by the scanner were modelled

The model also included the site topography. External elevations and perspective views were created and presented within the Revit model and, as requested by the client, also exported in DWG and PDF formats.



**Figure CS3.3**  
Architectural and structural detail integrated into the BIM modelling.

# Case Study 4

## The Oriental Club



**Figure CS4.1**  
BIM-derived view of Stratford House in  
Marylebone, London.

### Introduction

The Oriental Club is based in Grade I-listed Stratford House just off Oxford Street, Marylebone, London. It was designed by Robert Adam, the architect who designed Bath's iconic Pulteney Bridge. Stratford House was built between 1770 and 1776 for the 2nd Earl of Aldborough on the site of what was once the 16th-century Lord Mayor's banqueting house.

The Duke of Wellington established the Oriental Club in 1824 and it has been based in Stratford House since 1962. Its aim was to be an institution where gentlemen returning from the British Empire in the East could 'meet on a footing of social intercourse' and has included many notable figures amongst its membership. The club is now looking at carrying out improvements and repair work to Stratford House and has appointed van Heyningen and Haward Architects to lead the project.

### Why was BIM selected?

The architectural team at van Heyningen and Haward Architects is a long-time advocate of Building Information Modelling (BIM) for heritage projects, having used it for projects such as the rearrangement of Leicester Cathedral for the internment of Richard III; this experience was key in their selection by the Oriental Club. It was felt that working within a three-dimensional (3D) BIM environment was the only way to understand fully this complex historic structure and make the scheduling of the difficult conservation work considerably easier to control.

### How was the project undertaken?

The building consists of a basement, ground, first, second and third floors plus a fully accessible roof. Many rooms in the historic heart of the building contain panelling and considerable amounts of ornate plaster-work, all of which had to be laser scanned in full colour to provide the architects with a full high-definition 360-degree photographic record of the entire structure.

The project commenced with the establishment of an accurate survey control network using total stations. This was tied into UK Ordnance Survey (OS) national grid using a survey-grade global navigation satellite system (GNSS). Three laser scanners were used to capture a precise point cloud of every part of the building, with a total of 960 scans taken inside, externally and on the roof. Additional survey work was also carried out to show the surrounding topographic detail, and a closed-circuit television (CCTV) survey was carried out to gain a greater understanding of the drainage system running under the basement. In total around 160GB of scan data were collected by the survey teams, which were registered together as work progressed then passed over to the inhouse Revit® (Autodesk®) team for modelling.

The BIM showing the existing condition was produced by a team of five Revit modellers and completed in around 600 person hours. As with any project of this size and complexity, the team worked collaboratively throughout, individuals working on their own section of the model, with all the work being synchronised at the end of each day in the main master file.

### What was the deliverable output?

The final model was delivered in Revit 2016 and, after purging, was reduced down to a file size of 445MB. An existing condition model for a similar building would normally have a file size of around 100MB. As could be seen with this project, modelling intricate heritage architectural detail can increase BIM file sizes substantially.

### What problems were encountered?

The building contained a number of features, such as statues and carvings, that had to be shown in their true form in the model. Meshing techniques were employed by the modelling team to enable the creation of the more 'organic' geometry presented by these objects.

High-resolution scans were taken that were meshed using third-party software then built into the model using standard Revit family templates, to maintain a reasonable model size and avoid the need for importing non-Revit formats such as DWG files directly into the model space. The main staircases were particularly difficult to model accurately because of the intricate ironwork in the bannisters, much of it curving.



**Figure CS4.2 (Top)**

The statues and carvings as shown within the model.

**Figure CS4.3 (Bottom)**

The staircases and bannisters as shown within the model.

Producing the 360-degree photography was particularly challenging in some areas of the building because of bright sunlight pouring into dark rooms, but with a combination of light-emitting diode (LED) lighting and the use of the balanced exposure control on the laser scanners excellent results were eventually achieved.

### How was the BIM data used within the project?

The model had to show sufficient detail internally and externally, so that, as well as using the BIM for 3D work, the client could extract two-dimensional (2D) plan, section and elevation views from any position with a level of detail (LOD) equivalent to a 1:20 drawing. To be able to show this high LOD, all wood panelling, architraves, beading, cornices and any other ornate features had to be modelled throughout the entire building. Size can be a problem when creating a model of complicated heritage structures within a BIM environment, so extra care had to be taken when modelling the building's more ornate features in order to maintain a reasonable file size.

To help facilitate the production of a full repair schedule for all the historic sash windows in the building, a team from Bury Associates created a set of family parameters that allowed the identification of all the individual parts of each window so that their condition could be recorded. Each window family was set up to contain full details of the frame's components, as well as mullion sizes and each pane of glass.

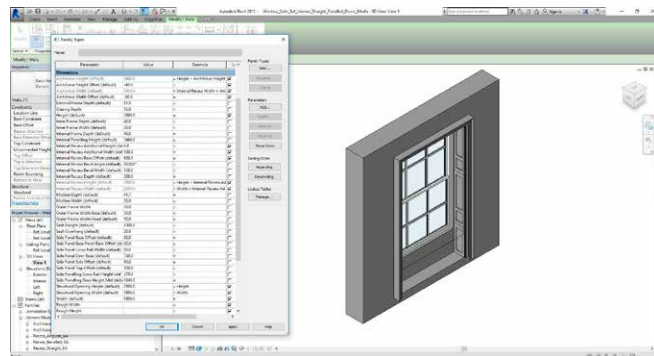

**Figure CS4.4**  
The family type parameters that allow the identification of individual parts of each window.

As with any major refurbishment project, providing the client with a good understanding of the existing services was essential. Stratford House contains a complicated network of heating, ventilation and air conditioning (HVAC), electricity, gas, water and heating systems, the major elements of which needed to be included in the BIM. Some of the mechanical, electrical and plumbing (MEP) systems were placed in extremely tight loft spaces, which proved challenging to scan. The MEP systems were incorporated into a separate linked model file that was referenced within the same coordinate system as the main model so that it could be used collaboratively by the project's mechanical and electrical (M&E) engineers.



# Case Study 5

## The Integration of Meshed Elements in a 3D BIM-ready Model

### Introduction

Greenhatch Group was asked to undertake a full measured building survey of a former post-office in Dundee, Dundee and Angus, Scotland, with a detailed Revit® (Autodesk®) model as the final output. Built in 1898, the post-office building is a category B-listed grey/cream sandstone ashlar three-storey structure with many impressive bipartite and tripartite windows, with Doric mullions flanked by Corinthian columns along with a balustraded parapet below a steeply pitched slate roof. The architects required a high level of detail (LOD) with visually and spatially accurate representations of the majority of the architectural features.



### Why was BIM selected?

The client for this project had been working within a Building Information Modelling (BIM) environment, specifically with Revit, for a number of years, preferring to use Revit from concept stage to the final detail drawings. Greenhatch Group has carried out a number of measured building surveys with the final output as a three-dimensional (3D) BIM-ready model for this particular client, and the client is now very adept at taking the spatially correct models and using them as a template to build up a proposal model complete with construction detailing. There are multiple advantages to this workflow. Visually accurate renders for planning and feasibility stages can be created quickly and easily, multiple plans and views for each stage of the construction process can be created, and the quantities required of materials and components scheduled. A model is generated that can act as a shared hub for contractors of all disciplines to develop their detail drawings. Once the build is complete, the final file acts as an accurate record of the project at each stage and can be handed over to the building staff to help asset management.

**Figure CS5.1**

Meadowside elevation of the former post-office building in Dundee.

### How was the project undertaken?

The on-site survey work was undertaken using a Leica TS15i total station theodolite in combination with a Zoller + Fröhlich 5010c phase-based scanner alongside traditional hand sketches and measurements taken using tape measures and Leica DISTOs. All scan locations were tied in to the control network using a minimum of four black and white checkerboard targets with the centre points coordinated by the total station. The office process used Leica's Cyclone to register the individual scans together, from which an e57 format file was exported to ReCap (Autodesk) to produce an RCP project to enable the use of the point cloud in Revit. The site was comprehensively scanned internally and externally which, along with the hand measurements, facilitated the creation of a full level of detail LOD 350 model of the post-office for use by the commissioning architects for their design work in planning a conversion of the building to a new campus for a nearby school.

When building up a 3D model, having point cloud data is generally invaluable, particularly on a project such as this where, because of the age of the building, many of the internal walls and floors do not run straight and true. In addition, the client had requested a high LOD on the external architectural features to allow production of accurate visual renders for use in planning proposals. To enable the modelling of these features, accurate data was needed to guide the production of the parametric families used to construct the final Revit model.

### What was the deliverable output?

The final model was released to the client as a Revit model set up with both a local grid on a prearranged project north, and the UK Ordnance Survey (OS) national grid. Within the issued file, sheets were set up for each floorplan, including the roof level, along with elevations and typical sections and rendered viewports throughout the structure. These were then exported as PDF sheets to be viewed by anyone without the required drafting software. Two-dimensional (2D) floorplans were also exported in DWG format so that the plans could be used in a more traditional

AutoCAD (Autodesk) or similar environment. With all projects, it is essential that all parties involved agree on which version of Revit will be used in advance of any modelling taking place, because Revit models are not backwards compatible. This was clarified at the point of tender.

Greenhatch Group specifies its final models as BIM ready rather than true BIM products, because it enters minimal building information in order to keep the models as lightweight as possible. When setting up a project, fields are created for each element so that any required information can be entered by either the client or any of the contractors throughout the life of the project. A survey notes project parameter is created, enabling comments about any element to be entered, whether it be information regarding tolerances or information about survey limitations in particular areas. These notes can be scheduled at any time to produce quickly a list of features to bring to the attention of the client.

### What problems were encountered?

While the on-site survey was carried out without significant incident, there were some elements of the building that proved quite troublesome to model using the standard out-of-the-box Revit tools. In particular, the principal elevation hosts two statues of winged females that would have been impossible to model natively in Revit. The client had specifically requested that these be included in the model, as they make up part of the building's listed status. The decision was made to incorporate a mesh created from the point cloud into a Revit family that could then be placed in the model at the correct coordinates, resulting in an object that was both geometrically correct in size and location, and would look graphically appealing in any rendered views. An area of scan points for the two statues was exported from the registration and a mesh was created using CloudCompare. This mesh was then cleaned and edited using MeshLab before reducing the number of faces so that it would have a smaller file size and not slow down the completed model. Exporting the completed mesh as a DWG file format enabled the insertion of the mesh into a Revit family which could then be loaded into the final model.

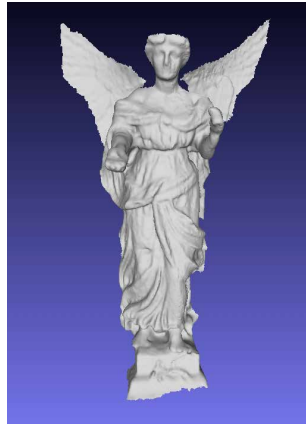
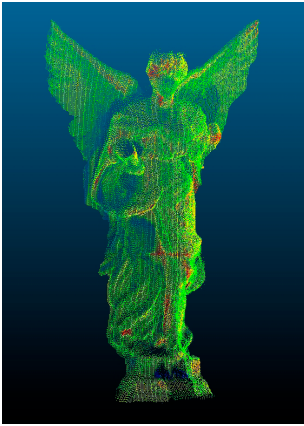

The first attempt at this process left a visually unappealing mesh as the edges of the triangles stood out clearly in stark contrast to the pale stone material chosen for the external model. This was greatly improved by editing the mesh using 3ds Max® (Autodesk) to render the edges invisible before integration into the Revit family. This resulted in a family that looked graphically correct both in standard drafting and rendered views.

### How was the BIM data used within the project?

By utilising scanning techniques along with a proven workflow, Greenhatch Group was able to complete all the site work within 5 days and had all site data processed and ready to work on within a day. Because of the extended timescales involved in producing a 3D model compared with traditional 2D line work, layout plans are produced that can be issued quickly to the client so that feasibility planning can be started while the model is being created. In this instance, the complete high-detail internal and external model took approximately 20 office days to produce, resulting in a final file size of 75MB along with a point cloud in RCP format of 5GB.



**Figure CS5.2 (Top left)**  
Scan data isolated for statue.

**Figure CS5.3 (Top right)**  
Mesh created from scan data.

**Figure CS5.4 (Middle)**  
Final rendered statue.

**Figure CS5.5 (Bottom)**  
Final model of the former post-office building in Dundee.



# Case Study 6

## Measured Building Surveys to BIM

### Introduction

This case study relates to a complex of buildings that was a secondary school in London. When the school relocated to newly built premises, the collection of buildings was sold to a local academy with plans to modernise the existing structures and reopen it as a free school. The complex consists of a matching pair of triple-bay Victorian-era school houses along with a modern modular multi-storey building and large sports hall. Greenhatch Group was commissioned to carry out a full measured building survey of the buildings once the current school had relocated, with the final output to be a model within a Building Information Modelling (BIM) environment to act as the basis for a series of works intended to modernise and refurbish the existing school buildings. The scope included the production of three-dimensional (3D) models of all the buildings on the site along with a topographical survey, also presented as a 3D element within the final file.



**Figure CS6.1**  
One of the two Victorian school buildings on-site.

### Why was BIM selected?

Not only was the final model to be used by the commissioning architects as a full measured building survey to act as the basis for their modernisation designs, but it was also to become a shared file between all disciplines involved in the construction and design works, with various companies modifying the final file to produce a full design model integrating the input from the architects, structural engineers and interior designers. Once the building works were complete, the model would then continue to be used by the estates management team working for the school as an asset management tool. As this was made clear within the initial brief, key parameters and nested families could be incorporated within the project that would aid the process once the model had been passed on to the end-user.

### How was the project undertaken?

The on-site survey work was carried out with Greenhatch Group's standard method of using phase-based laser scanners to capture point cloud data for the external areas and principal open spaces, in combination with the use of a total station to coordinate the scan locations by recording the centre points of at least four black and white checkerboard targets for each scan location, as well as carrying out a full traverse of all areas of the buildings to position the geometry accurately. These surveys were backed up by traditional hand sketches and measurements with a full photographic record throughout. The topographical survey was carried out traditionally using a total station and detail pole to create a full 3D surface that could be imported directly into Revit® (Autodesk®). Cyclone (Leica) was used



**Figure CS6.2**

All buildings on-site were surveyed and modelled.

---

in conjunction with ReCap (Autodesk) to process the scan data into a format compatible with Revit. The complete package of data facilitated the creation of a full level of detail (LOD) 350 model of all buildings within the site.

Once all the data was processed and set to the UK Ordnance Survey (OS) national grid, basic layout plans were created in AutoCAD (Autodesk) to form the basis of the model creation. As AutoCAD handles real-world coordinates far more accurately than Revit, it is advantageous to produce basic plans for the site into which the model can be exported to confirm the accuracy of the location of the final model. Because of the internal 20km limit built into Revit, two site locations were created: a local grid, where a physical, permanent on-site station marker was set to 0,0, and another grid with real-world coordinates. All modelling was carried out on the local coordinates to ensure that the survey data displayed at the correct location, before the model was set to OS coordinates for exporting to AutoCAD and being issued to the client.

### What was the deliverable output?

There were multiple deliverable outputs as part of the final product, including a full model in RVT and IFC formats along with a 3D DWG export. Sheets were also set up within the RVT file to show the individual floorplans along with typical sections and elevations of each structure within the site. A copy of all the scan data was issued to the client in both e57 and RCP formats to ensure compatibility with various systems. An interactive hypertext mark-up language (HTML) file of the floorplans was also set up with links to TruView (Leica) outputs

of each scan location to enable viewing of all the collected data by parties unable to process and host large 3D point clouds. All data was issued to the end-users via universal serial bus (USB) devices and was hosted securely on internal servers with access set up for any involved parties.

Greenhatch Group was asked to ensure that the schedules could be set up for all items within the project, paying particular attention to the Victorian-era windows and glazing. Typically, within Revit, individual windows can be quickly and easily scheduled by type or other constraint, however in this case the client requested that each individual pane of glass within the windows and doors could be scheduled to allow the model to be used for asset management and condition reports. To enable this, a glass pane family was created that could be nested into each custom-made window and door family, with a shared parameter that would report back to the main model. Once complete, the window schedule consisted of more than 2,300 individually numbered glass panes, allowing each one to be updated with its current condition so that a list of works and maintenance could easily be created.



**Figure CS6.3**

Individually selectable window panes.

---



**Figure CS6.4**  
Final rendered model of the Victorian school building.

### What problems were encountered?

Because of the age of the main school buildings, the roofs had spread, causing the exterior walls to bow outwards. After discussions with the client, tolerances were set for the modelling of any vertical deviation and these elements were dealt with in one of two ways. In areas where the deviation was within 30mm, a text note was added to a survey notes parameter built into each element that specified the true deviation. The walls were then modelled as vertical based on their position at a cut-off point of 1500mm up the face of the wall. Where the deviation from plumb was greater than the 30mm cut-off point, the wall was modelled with a thickness equalling the true wall depth plus the amount of deviation. A face-based wedge-shaped void was then applied to the internal and external face of the walls, resulting in a wall with trapezoid geometry that accurately followed the point cloud. Carrying out the modelling in this way, as opposed to using a model in place or massed object, ensured that the wall still functioned as a wall within Revit, allowing the hosting of architectural elements and correct scheduling.

### How was the BIM data used within the project?

The size of the project and the number of buildings meant that 12 days were needed on-site to capture fully the scan data suitable for use as a base for the model. The collected data was processed and issued to the client along with basic two-dimensional (2D) layout plans within a week, with the full modelling of the site, including topographical survey, in around 4 weeks, using multiple Revit technicians. The final issued model was an 85MB file, accompanied by scan data in RCP format, split into individual floors and buildings to maintain usability, totalling 15GB, together with an interactive HTML-based TruView product of 14GB.

# Case Study 7

## Public Areas and External Façade Laser Scanning and Revit Modelling

### Introduction

With the aim of improving its existing building records and information, the Natural History Museum Estates Department commissioned a laser scan survey of all its publicly accessible areas and external building façade in South Kensington, London. The publicly accessible areas comprise 29 galleries, 4 shops and 6 cafes. The Waterhouse Building, which opened in 1881, is Grade I listed, and the whole estate lies entirely within the Queen's Gate conservation area, designated by the Royal Borough of Kensington and Chelsea.

### Why was BIM selected?

One of the aims of the Museum's strategy to 2020 is to prioritise and make an impact in digital technology and innovative platforms. Building Information Modelling (BIM) has been identified as an effective information management tool for both existing and incoming as-built information.

The goal of the project was to have a base architectural model that can be used to aid the collaborative design and delivery of future building projects. Other services can be added to the model as building projects are designed and delivered. Having a three-dimensional (3D) model also allows the extraction of accurate two-dimensional (2D) plans, sections and elevations of any area that is modelled, information that the Museum has previously struggled to find and provide.

### How was the project undertaken?

The project specification was generated in collaboration with the Museum to ensure limitations were recognised, expectations were met and the final use of the information was fully understood by those capturing and modelling the data. Both Leica and FARO® laser scanners were used to acquire the data, the Leica P20 to record the exterior and traverse through the building, and the FARO X330 to scan the interior spaces. Colour was captured with a NCTech iSTAR camera supplemented by an on-board scanner camera. All data registration was performed in Leica Cyclone software, predominantly using the traverse and cloud-to-cloud registration techniques. The latter proved beneficial in several ways. It sped up both the data collection and registration workflows, and limited the need to position targets within the Museum, which was of concern to the building conservators. Some permanent markers were positioned externally and internally to aid the coordination of any future survey work. Using a resourceful registration method, the interior galleries could easily be registered to control as standalone datasets or combined with the full building traverse (exterior and interior) scan data to facilitate a manageable and comprehensive quality assurance (QA)/quality control (QC) process.



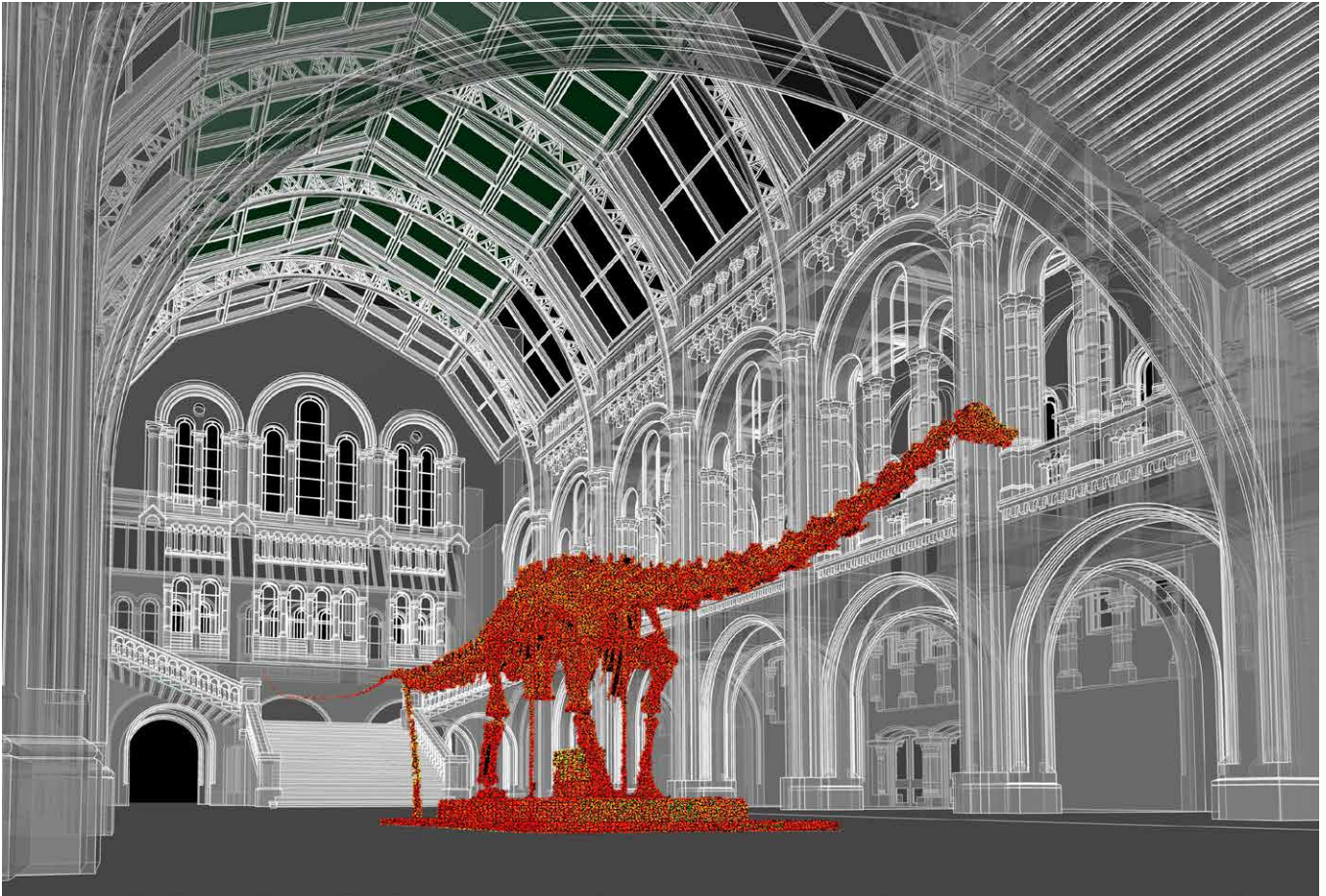

**Figure CS7.1**  
Hintze Hall entrance space within the Natural History Museum.

Providing an efficient scan database that could be fully utilised by the client was an important consideration when undertaking this project. The Museum required a complete-as-possible dataset with limited shadowing. It also wanted a usable dataset, so the final size of the data had to be kept to a minimum. With more than 2,000 coloured scans, the dataset still proved to be large (c 1.4TB) and so was partitioned per building.

The same applied to the Revit® (Autodesk®) model. Each building was modelled separately but they could be linked together sharing the same project basepoint. Modelling was performed in Revit using Leica Cloudworx. Architectural elements were modelled as families to the agreed level of tolerance, with finer details simplified to keep the size of the model to a minimum. The Museum comprises a series of interlinked buildings of differing ages and styles. Each required its own library of families, built by Mollenhauer's inhouse team.

#### **What was the deliverable output?**

The deliverables included the point cloud, a 3D model and a panoramic point-cloud viewer. The 3D model was produced to an agreed level of detail (LOD) and tolerances (LOD 200 for the interior spaces and LOD 300 for the exterior façade). The point cloud and the panoramic point-cloud viewer allow the Museum to add further detail onto the model as and when needed in the future.

#### **What problems were encountered?**

Because of the number of visitors that the Museum receives, the scans had to be done out of normal operating hours. Even out of normal operating hours, the programme had to be scheduled around evening events, which could go on till 03.00. This scenario posed problems with lighting. Additional security was also needed when working in sensitive areas. Because of the limited time on-site, the scanning was conducted over a period of 3 weeks.

The model was to include the architecture only, not the exhibits. Although in most areas enough architecture was exposed to provide the information required, in some areas the entire space was occluded by the exhibit. In these areas assumptions had to be made and it is intended that these areas will be revisited when the exhibit is being replaced in the future and the model updated accordingly.

### How was the BIM data used within the project?

The BIM-ready Revit model provides a geometrically accurate base model that can be used for facilities management, project coordination and future design work. Initially the data will be used predominantly by the estates department, with the Revit models linked to the Museum's existing facilities management tool. Other parties within the Museum have shown an interest in using the data and it is anticipated that the BIM will be used successfully as a single source of accurate survey information. The BIM environment will provide a working model to which additional information can be added over time as galleries become vacant, revealing the once-hidden architectural features and services.

# Case Study 8

## IWM Lambeth Road Laser Scanning and Modelling

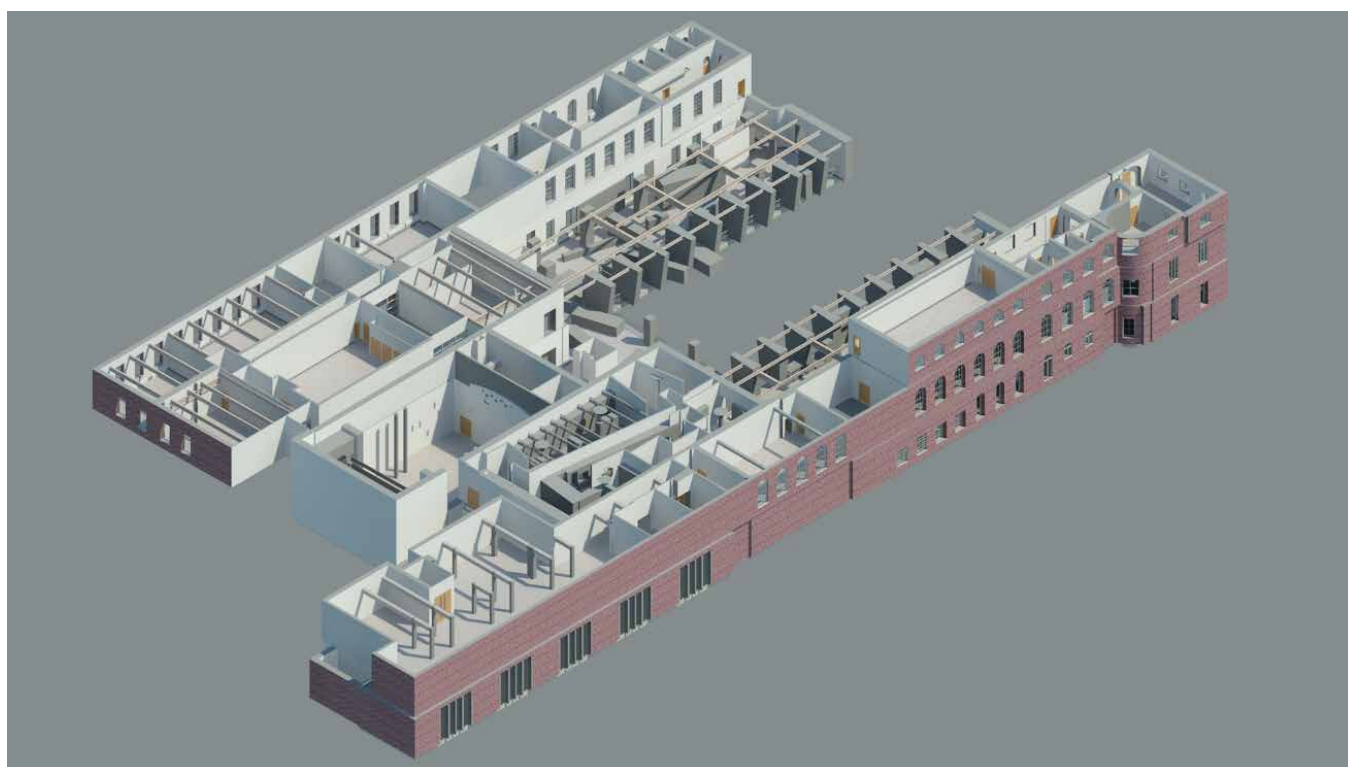

**Figure CS8.1**  
Overview of Revit model data for the Imperial War Museum.

### Introduction

Stanburys Ltd was approached by Fraser Randall acting on behalf of the Imperial War Museum (IWM) to undertake a laser scanning and modelling exercise as part of a major Building Information Modelling (BIM)-driven refurbishment of large parts of the museum space at Lambeth Road, London.

Areas to be upgraded and improved included main exhibition halls, libraries, museum

stores, training and education areas, as well as administrative and clerical spaces.

Notably for Stanburys, this involved conducting a laser scan of all the internal areas required and producing the initial computer-generated three-dimensional (3D) model to an agreed level of detail (LOD 300), which would then be further developed and utilised by various consultants, engineers and architects as the central part of the BIM-driven project.



### Why was BIM selected?

BIM was selected for this project to enable close coordination by all parties involved in the refurbishment, ensuring that the most-up-to-date and relevant dataset was available at all times, minimising clashes and ensuring service, architectural and structural changes could be run and implemented in the most efficient manner possible. It was also a requirement that a model was available to enable planning of transit routes for exhibits, as the routes used previously for the relocation of larger exhibits had been decommissioned and infilled with concrete.

### How was the project undertaken?

Survey control was established externally in the form of a closed-loop traverse using a total station and global positioning system (GPS) solution that enabled referencing of the data to the UK Ordnance Survey (OS) national grid. A further traverse through the building was then undertaken, during which pre-positioned internal scan target positions were observed to facilitate georeferencing of the scan data itself.

Two FARO® FocusS 3D terrestrial laser scanners were used in multiple positions internally to capture fully the areas of the structure required, with approximately 300 scan locations being occupied

Colour data was collected via the on-board cameras in addition to the intensity-based scan data. Scan positions were linked using checkerboard targets and reference spheres. The data was collected over three nights.

Processing and collation of the scan data was undertaken using FARO SCENE software, with survey control imported via CSV files to improve the quality of the registration. Further enhancement of the registration was achieved by using small clusters of no more than 15 scan positions within the main registration file for each floor. Floors were then imported into one large scan project incorporating all of the areas affected by the refurbishment.

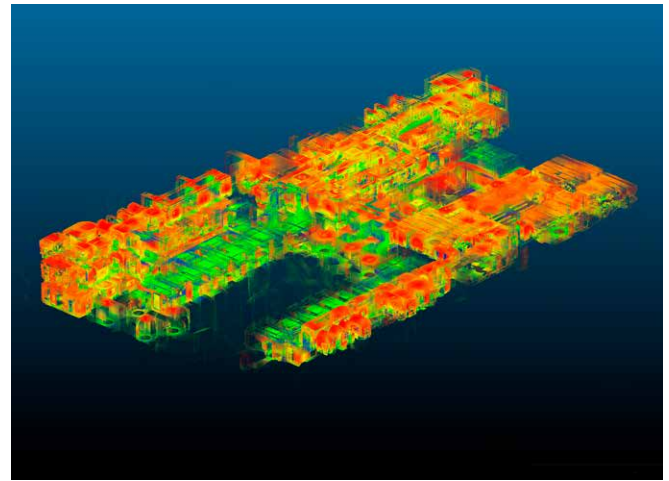

**Figure CS8.2**

Scan data showing a sample of positions occupied.

---

Once registered, the point cloud data was exported in e57 file format, and a SCENE WebShare (standalone web-based viewing software by FARO) output of the complete scan project was created. The e57 file was then imported into Revit® (Autodesk®) software. In all, registration and processing of the scan data took approximately 3–4 days to complete.

Modelling was usually undertaken in Revit, using the registered point cloud as a template that could be sliced or sectioned accordingly to ensure that the model was constructed to suitable tolerances. While all the structural elements were modelled to LOD 300, it was agreed that the exhibits themselves, where required, could be represented in simple block form as long as the overall dimensions of each were modelled. The modelling process itself took around 3 working weeks to complete.

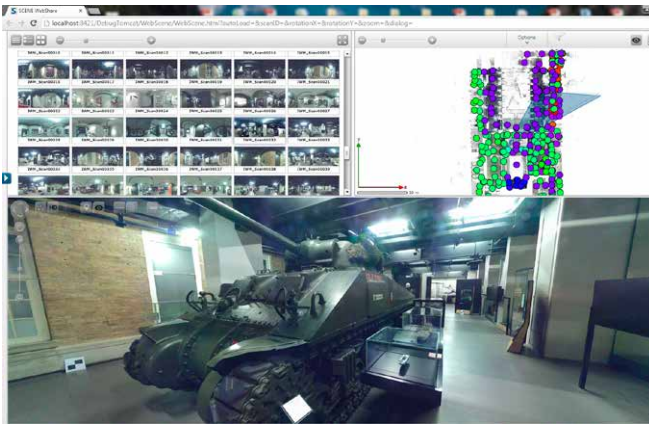

**Figure CS8.3**  
Screenshot of FARO WebShare data.



**Figure CS8.4**  
Rendering of display area showing simple block representation of exhibits.

### What was the deliverable output?

A WebShare output of the entire scan project was supplied to the client as a visual record of the environment within the IWM at Lambeth Road. This enabled the client to interrogate the survey data fully, extracting measurements or coordinates/levels and even mark-up/annotate the data and export screen shots if required.

Scan data was also supplied in registered e57 file format, the industry-recognised standard for laser scan data, which should enable future import into most (if not all) laser scan software solutions.

A Revit model (RVT file format) was supplied along with a rendered walkthrough in AVI format, also produced in Revit. This, as previously mentioned, was to include all structural and service detail where required to LOD 300, with exhibits. The data for the Revit model was also requested and delivered in IFC file format for further development in Vectorworks® (Nemetschek) and other software solutions

In terms of data size and capacity, the larger items were the registered scan data and the WebShare output, which amounted to approximately 70GB of information. The exported scan data was sampled to keep the e57 file size to a minimum but this still amounted to several gigabytes. The modelled data itself was relatively small in comparison, amounting to less than 200MB.

It is interesting to note the disproportionate relationship between the size of the laser scan data against the final modelled outcome.

### What problems were encountered?

While no major problems were encountered during the survey, the requirement for scans to be collected with colour photographic overlay using the built-in digital camera did mean that data collection times were significantly longer than they would have been with native intensity-based data. Because the survey was conducted over several nights, there was a potential issue with the removal of self-adhesive reference labels during the day by cleaning staff, which could have inhibited progress. However, previous experience in similar environments meant that a degree of disruption was anticipated, and additional labels were placed in slightly inaccessible areas to compensate for this. From a modelling perspective, no major problems were encountered.

### How was the BIM data used within the project?

So far, the model has been developed further by the client and members of the design team to facilitate services and architectural/structural design, with the model being used as the central hub of the ongoing BIM refurbishment project for the building, which is due to be completed c 2021. A second phase of scanning has been undertaken, with additional modelling of the data to be undertaken in due course.

# 6 Where to Find Out More

A wealth of information on BIM, providing advice and guidance about adopting BIM in heritage projects, as well as free software and tools, can be found online and within books and journals, via organisations and special interest groups. Although not necessarily specific to heritage (other than the BIM4Heritage website, see [section 6.2.2](#)), a lot of the information found in the following resources can be applied to cultural heritage and conservation projects adopting BIM-enabled workflows.

## 6.1 Standards and guidance

### 6.1.1 Architectural, Engineering and Construction (AEC) Industry (UK) Initiative

The AEC (UK) Initiative offers practical guidance for the adoption of BIM standards in the form of the *AEC (UK) BIM Technology Protocol* (AEC (UK) 2015), with additional documents available for the most widely used BIM software. These are all available to download as free PDF files.

<https://aecuk.wordpress.com/documents/>

### 6.1.2 British Standards Institution (BSI) BIM Level 2

A series of British standards (BS) and publicly available specifications (PAS) has been developed to help the construction industry adopt BIM Level 2. Although not specific to Historic BIM, these documents are an essential point of reference for professionals and clients implementing BIM in the heritage sector. The webpages provide information, guidance, standards and online tools. The documents can be downloaded for free. A full glossary of BIM acronyms and terms is also available.

<http://bim-level2.org/>

<http://bim-level2.org/en/standards/>

### 6.1.3 Historic England (HE)

For guidance and a detailed specification on the use of recording techniques, the latest edition of Historic England's *Metric Survey Specifications for Cultural Heritage* (Andrews *et al* 2015) contains a short section on acquiring BIM-ready datasets. Also available from Historic England are technical guidance documents on a range of survey and recording techniques for cultural heritage. These documents are available to download for free as PDFs or printed copies can be purchased.

<https://historicengland.org.uk/advice/technical-advice/recording-heritage/>

<https://historicengland.org.uk/research/approaches/research-methods/terrestrial-remote-sensing/specialist-survey-techniques/>

#### 6.1.4 National Building Specification (NBS)

Guidance on the creation of BIM objects in the form of the NBS Object Standard is available on the NBS website. Also available are online resources providing free guidance, tools, plug-ins, standards, and more. The NBS BIM Toolkit provides step-by-step help to define, manage and verify responsibility for information development and delivery at each stage of the asset life cycle. It is a free tool developed to assist the UK construction industry achieve BIM Level 2. The NBS National BIM Library is an ever-expanding repository of BIM objects, available for download in proprietary or IFC format, all compliant with the NBS Object Standard. The website also provides information on COBie and the Uniclass 2015 classification scheme.

<https://www.thenbs.com>

<https://www.thenbs.com/about-nbs/introducing-nbs>

<https://www.thenbs.com/services/our-tools/nbs-bim-object-standard>

<https://toolkit.thenbs.com/>

<https://toolkit.thenbs.com/articles/classification#classificationtables>

<https://www.nationalbimlibrary.com/>

<https://www.nationalbimlibrary.com/about-bim-objects>

<https://www.thenbs.com/knowledge/bim-mapping-out-the-legal-issues>

## 6.2 Organisations and special interest groups

### 6.2.1 Archaeology Data Service (ADS)

The ADS promotes good practice in the use of digital data in archaeology, provides technical advice to the research community and supports the deployment of digital technologies.

<http://archaeologydataservice.ac.uk/>

### 6.2.2 BIM4Heritage

BIM4Heritage is a special interest group established within BIM4Communities to champion BIM within the historic environment. The group is formed by various specialists, for example from within the AEC industry, conservation, heritage organisations, academic departments and end-users. The vision of the BIM4Heritage group is to provide a forum for organisations and industry professionals to share knowledge and lessons learnt on BIM applied to historic structures. Its webpages provide papers on and technical standards for the application of BIM within the field of heritage, as well as information and updates on the activities of the BIM4Heritage special interest group (operating within BIM4Communities).

<http://bim4heritage.org>

### 6.2.3 BIM Task Group

The BIM Task Group brings together expertise from industry, government, public sector, institutes and academia with the aim of supporting the UK public sector and construction industry to implement BIM. An extensive list of free BIM viewers is available from the BIM Task Group website, and guidance is available on the use of the CIC BIM protocol and professional indemnity insurance.

<http://www.bimtaskgroup.org>

<http://www.bimtaskgroup.org/free-bim-viewing-tools>

<http://www.bimtaskgroup.org/bim-eirs/>

<http://www.bimtaskgroup.org/bim-protocol/>

<http://www.bimtaskgroup.org/professional-service-indemnity-insurance-guidance/>

### 6.2.4 Building Research Establishment (BRE)

The BRE website provides information on certification schemes for individuals and organisations.

<http://www.bre.co.uk/>

### 6.2.5 BuildingSMART

BuildingSMART is an international authority on open BIM and IFC standards.

<http://buildingsmart.org/>

### 6.2.6 Construction Industry Council (CIC)

The CIC provides a forum for organisations within the construction industry.

<http://cic.org.uk/>

### 6.2.7 Construction Project Information Committee (CPIC)

The CPIC provides a BEP template that can be downloaded.

<http://www.cpic.org.uk/cpix/cpix-bim-execution-plan/>

[www.cpic.org.uk/cpix/](http://www.cpic.org.uk/cpix/)

### 6.2.8 Council on Training in Architectural Conservation (COTAC)

COTAC works to raise standards, develop training qualifications and build networks across the UK's conservation, repair and maintenance (CRM) sector, currently estimated to represent more than 40% of all construction industry activities. Following a number of conferences on the theme, in 2014 COTAC initiated an ad-hoc BIM4Conservation group that was integrated with the BIM4Heritage group in 2016. Various online conference reports, presentations and publications on the subject of Historic BIM are available on the COTAC website.

<http://cotac.global>

- *Past Caring? BIM and the Refurbishment of Older Buildings* (2012)  
<http://cotac.global/conferences/conf12/>
- *Integrating Digital Technologies in Support of Historic Building Information Modelling: BIM4Conservation (HBIM)* (2014)  
<http://cotac.global/resources/COTAC-HBIM-Report-Final-A-21-April-2014-2-small.pdf>

- *Fire and Flood in the Built Environment: Keeping the Threat at Bay* (2015)
- *COTAC BIM4C Integrating HBIM Framework Report Part 1: Conservation Parameters* (2016)  
<http://cotac.global/resources/HBIM-Framework-Part-1-February-2016.pdf>
- *COTAC BIM4C Integrating HBIM Framework Report Part 2: Conservation Influences* (2016)  
<http://cotac.global/resources/HBIM-Framework-Part-2-February-2016.pdf>
- *COTAC BIM4C integrating HBIM Framework Report Bibliography: Version 1* (as at 26 July 2016)  
<http://cotac.global/resources/HBIM-Framework-Bibliography-Ver-1-26-July-2016.pdf>
- *BIM4Heritage: Where We Are and Where We Are Going* (2017)

### 6.2.9 Historic Environment Scotland (HES)

HES is a public body that provides advice and guidance relating to heritage management

<https://www.historicenvironment.scot/>

### 6.2.10 Royal Institute of British Architects (RIBA)

RIBA provides professional standards and support for its members.

<https://www.architecture.com/RIBA/Home.aspx>

### 6.2.11 Royal Institute of Chartered Surveyors (RICS)

The RICS provides guidance and training schemes, including BIM manager certification.

<https://www.rics.org>

### 6.2.12 Scottish Futures Trust (SFT)

The SFT's BIM Portal is an online resource designed to support public sector procurement of BIM Level 2 in Scotland. The BIM Portal provides a wealth of information and free tools that are useful for private-sector BIM clients and suppliers across the UK, such as the BIM Compass. The BIM grading tool is an online assessment tool based on user input that determines the BIM maturity level appropriate for a project, designed to support public procurers in Scotland. The ROI calculator enables self-assessment of the benefits of BIM for a construction project.

<https://www.scottishfuturestrust.org.uk>

<https://bimportal.scottishfuturestrust.org.uk>

<https://bimportal.scottishfuturestrust.org.uk/page/bim-compass>

### 6.2.13 Survey4BIM

Survey4BIM is a cross-industry group open to all organisations involved in the survey, collection, management, processing and delivery of geospatial information within a BIM context. It is supported by the BIM Task Group.

<http://www.bimtaskgroup.org/survey4bim/>

## 6.3 Publications

### 6.3.1 Books

At the time of writing, only one book dedicated to the subject of Historic BIM has been published.

Arayici, Y, Counsell, J, Mahdjoubi, L, Nagy, G A, Hawas, S and Dweidar, K 2017 *Heritage Building Information Modelling*. London: Routledge

However, the following books are also relevant to the use of BIM technology in the field of cultural heritage.

Aubin, P and Milburn, A 2013 *Renaissance Revit: Creating Classical Architecture with Modern Software*. Oak Lawn, IL: G3B Press

Eastman, C 2011 *BIM Handbook: A Guide to Building Information Modeling for Owners, Managers, Designers, Engineers and Contractors*, 2 edn. Hoboken, NJ: John Wiley & Sons Inc

Holzer, D 2016 *The BIM Manager's Handbook: Guidance for Professionals in Architecture, Engineering and Construction*. Hoboken, NJ: John Wiley & Sons Inc

Klaschka, R 2014 *BIM in Small Practices: Illustrated Case Studies*. London: RIBA Enterprises

Klemisch, J 2011 *Maintenance of Historic Buildings: A Practical Handbook*. Shaftesbury: Donhead Publications

Mordue, S, Swaddle, P and Philp, D 2016 *Building Information Modeling for Dummies*. Chichester: John Wiley and Sons Inc

Osello, A and Rinaudo, F 2016 'Cultural heritage management tools: the role of GIS and BIM, in Stylianidis, E and Remondino, F (eds) *3D Recording, Documentation and Management in Cultural Heritage*. Dunbeath: Whittles Publishing

### 6.3.2 Journals and conference proceedings

Providing a complete list of peer-reviewed academic research papers on the subject of BIM, even one limited to Historic BIM, is outside the scope of this document.

Articles relevant to Historic BIM can be found in the International Society for Photogrammetry and Remote Sensing (ISPRS) archive and the International Committee for Documentation of Cultural Heritage (CIPA) conference archives. Online conference reports, presentations and publications on the subject of Historic BIM are available on the COTAC website (see also [section 6.2.7](#)).

<http://www.isprs.org/publications/Default.aspx>

<http://cipa.icomos.org/>

<http://cotac.global>



The following publications contain content relevant to Historic BIM:

- AEC Magazine  
<http://www.aecmag.com/>
- Applied Geomatics  
<http://link.springer.com/journal/12518>
- Automation in Construction  
<https://www.journals.elsevier.com/automation-in-construction/>
- BIM Journal  
<http://www.bimjournal.com/>
- Engineering, Construction and Architectural Management  
<http://www.emeraldinsight.com/journal/ecam>
- International Journal of 3-D Information Modeling (IJ3DIM)  
<http://www.igi-global.com/journal-contents/international-journal-information-modeling-ij3dim/41967>
- International Journal of Architectural Computing  
<http://www.architecturalcomputing.org/jour/>
- Journal of Information Technology in Construction (ITcon)  
<http://www.itcon.org/>
- The Structural Engineer  
<https://www.istructe.org/thestructuralengineer>

## 6.4 Further online resources

### 6.4.1 B1M

Although not specific to heritage, B1M is an online library of videos explaining various topics around BIM.

<http://www.theb1m.com/>

### 6.4.2 BIM Dictionary

The BIM Dictionary is a free online resource providing definitions of hundreds of BIM terms and abbreviations.

<http://bimdictionary.com/#>

### 6.4.3 Digital Built Britain

Digital Built Britain provides further information on BIM Level 3.

<http://www.digital-built-britain.com/>

### 6.4.4 OpenBIM

OpenBIM provides the xBIM toolkit.

<http://www.openbim.org/>



# 7 Glossary

**2D** Two dimensional representation using coordinate values relative to the X and Y axes

**3D** Three dimensional representation using coordinate values relative to the X, Y and Z axes

**4D** Three dimensional representation using coordinate values relative to the X, Y and Z axes with the inclusion of time-related information

**AEC** Architecture, Engineering & Construction

**AECO** Architecture, Engineering, Construction & Operations (industry)

**AIA** American Institute of Architects who developed the levels of development framework to specify the degree of reliability of model information

**AIM** Asset Information Model, refers specifically to the information model used to manage, maintain and operate an asset

**AIR** Asset Information Requirements, define the information required at project handover stage to enable the safe and effective operation of the asset

**Asset** Item of property owned by a person or company

**BEM** Building Energy Modeling used to predict the energy use of a building

**BEP** BIM Execution Plan defines the strategy for project delivery using BIM

**BIM** Building Information Modelling, a collaborative process for the production and management of structured electronic information and illustrating, in digital terms, all the elements that compose a building

**BIM-ready** A 3D model formed as an assembly of native BIM components which represents the geometry of the existing fabric

**BSI** British Standards Institution, the independent national body responsible for preparing British Standards and other standards-related publications, information and services

**CAD** Computer-Aided Drawing/Design, used to describe graphics packages used primarily in engineering and design. As these disciplines require a high degree of precision, they are also ideal for survey applications

**CAFM** Computer-Aided Facility Management, the support of facility management by information technology to track, manage, report, and plan facilities operations

**CAPEX** Capital Expenditure, one-off expenditure that results in the acquisition, construction or enhancement of fixed assets including land, buildings and equipment

**Carbon performance** A measure of the carbon emissions from the operation, use and maintenance of an asset and the emissions associated with the users of the asset

**CCTV** Closed-Circuit Television, the use of video cameras to transmit images to a limited number of televisions on the same network or circuit

**CDE** Common Data Environment, the framework used to support interdisciplinary collaboration through BIM that specifies a single source of information for the project, used to collect, manage and disseminate project information through strictly controlled processes

**CIC** Construction Industry Council, the representative forum for the professional bodies, research organisations and specialist business associations in the construction industry

**Clash detection** Identification, inspection and reporting of interferences in a 3D project model

**Closed-loop traverse** A closed traverse that begins and ends at the same point thus creating a closed geometrical polygon shape

**Cloud based** Applications, services or resources made available on demand via the Internet from a cloud computing provider's servers

**COBie** Construction Operations Building information exchange, a data-exchange format that supports the exchange of information about new and existing buildings and infrastructure throughout their life cycle

**Control points** A point on the ground or building that has pre-observed three dimensional co-ordinates

**Corinthian** The last developed and most ornate of the three principal classical orders of ancient Greek and Roman architecture characterised by fluted columns and elaborate capitals decorated with acanthus leaves and scrolls

**COTAC** Council on Training in Architectural Conservation, a UK-registered charity that aims to improve the standard of education for all those involved in the protection, preservation, and sustainability of the historic environment

**CRM** Conservation, Repair and Maintenance (sector)

**CSV** Comma-Separated Values, a simple plain text file format used to store tabular data such as a spreadsheet or database

**Deliverables** Goods or services that will be provided upon completion of a project

**Desk-based assessment** The summary, collation and/or synthesis of existing research, assessments and management of legacy information

**DGN** The native CAD drawing file format used by Bentley Systems MicroStation software

**Doric** One of the three principal classical orders of ancient Greek and Roman architecture characterised by simple circular capitals at the top of columns

**Drone** An unmanned aircraft, also known as Remotely Piloted Aircraft Systems (RPAS), Small Unmanned Aircraft (SUA) or Unmanned Aerial Vehicle (UAV), that are normally flown by a pilot from a distance using a remote control station that communicates instructions to it

**DWG** The native CAD drawing file format used by AutoCAD software

**DXF** Drawing Exchange Format, a digital data format developed by Autodesk® and used for transferring digital map, plan or survey data between various CAD and graphics software packages

**E57** A universal, vendor-neutral format, named after the committee that devised it, for storing point clouds, images, and metadata produced by 3D imaging systems such as laser scanners

**EIR** Employer's Information Requirements, pre-tender document setting out the information to be delivered and the standards and processes to be adopted by the supplier as part of the project delivery process to enable the safe and effective operation of the asset

**Enterprise system** Asset management, computer-aided facility management (CAFM), geographical information systems (GIS), databases and archives used to manage information about an asset/estate

**Family templates** Serve as building blocks for creating element families that contain the shared information needed to start a BIM modelling project

**Federated discipline-specific models** An assembly of the discipline-specific models that contain 3D geometric and non-graphical data and associated documentation

**Geophysics** The application of physics to study the earth and detect past human activity beneath the ground that plays a vital role in the discovery and understanding of archaeological sites

**GIS** Geographical Information System, a system comprising a spatially referenced computer database and application software for capturing, storing, checking, integrating, analysing and displaying data that are spatially referenced to Earth

**GNSS** Global Navigation Satellite System, the generic term for satellite navigation systems that provide global coverage including GPS, GLONASS, Galileo and BDS

**GPS** Global Positioning System, specifically the name for the satellite constellation operated by the USA but also a generic term used to describe surveying or navigation by reference to a satellite constellation

**H&S** Health and Safety, the laws, rules, and principles intended to keep people safe from injury or disease at work and in public places

**HTML** HyperText Markup Language, the standard markup language for creating and structuring web pages

**HVAC** Heating Ventilation and Air Conditioning, the technology of indoor environmental comfort that provides heating and cooling services to buildings

**IFC** Industry Foundation Class, an object-based open standard for the exchange of BIM information between different software. Developed by 'buildingSMART', a global alliance specialising in open standards for BIM, IFC is an official standard, BS ISO 16739, and contains geometric as well as other data

**Intangible characteristics** Identifiable non-monetary assets, such as heritage values and significance, that cannot be seen, touched or physically measured and are created through time and effort

**Intellectual property** Creative work which can be treated as an asset or physical property

**IPR** Intellectual Property Rights, rights granted to creators and owners of works that are the result of intellectual activity

**IT** Information Technology, the application of computers to store, study, retrieve, transmit, and manipulate data or information

**JPEG** Joint Photographic Experts Group, a standard file format for compressing pictures so they can be stored or transmitted

**Landscape survey** The recording and analytical investigation of sites and areas on the ground

**Laser scanning** An active, fast and automatic acquisition technique using laser light for non-contact measurement of 3D coordinates of points on surfaces in a dense regular pattern

**Legacy information** Information already available on a historic asset which may exist in paper or electronic format, on-site or dispersed in several off-site locations and potentially under intellectual property or security restrictions

**Lidar** Light detection and ranging, a system frequently deployed from a plane or helicopter that uses laser pulses to measure the distance to an object or surface, typically determining the distance by measuring the time delay between transmission of a pulse and detection of the reflected signal

**LOD** Level Of Detail, how much geometric detail is included in BIM components and refers only to the appearance of the object geometry not the amount of associated information

**LOI** Level Of Information, the description of non-graphical content of models at each of the stages defined for example in the CIC Scope of Services

**M&E** Mechanical and Electrical, refers to systems that include infrastructure, plant and machinery, heating, plumbing and ventilation

**Measured survey** The process of measurement for buildings and sites to provide an accurate, reduced scale representation showing the required structural elements and architectural features

**Medieval** Related to the Middle Ages, the period in European history from 5th to the 15th century

**MEP** Mechanical, Electrical and Plumbing, the three engineering disciplines that BIM typically considers

**Mesh surface models** Three dimensional models containing vertices, edges and faces that define the surface shape of an object

**Meshing** The process of generating a polygonal or polyhedral mesh through the interconnection of three dimensional vertices

**Metadata** Data that describes other data and facilitates the re-use and long-term preservation of 3D survey datasets

**Metric survey** The use of precise and repeatable measurement methods to capture spatial information for reproduction at scale

**Modelling tolerance** How accurately a model fits against the as-existing survey, usually a point cloud dataset

**Mullion** A vertical bar that forms a division between the openings in a window, door or screen

**Native BIM** The original component creation process used for representing the geometry of existing fabric

**Neoclassical** Revival of classical style from ancient Greece and Rome that began in the mid-18th century

**Non-geometric information** Tangible and intangible values for the built fabric such as materials, appearance and condition, environmental, structural and mechanical performance, load-bearing capacity and standard compliance

**Non-native geometry** Geometric data derived outside the original component creation process that is not parametric, cannot be easily edited nor interacts well with other BIM components

**O&M** Operation and maintenance, the daily activities and services needed to ensure an asset performs to its intended function

**OBJ** Text based file format developed by Wavefront Technologies for defining three dimensional object geometry

**OIR** Organisational Information Requirements establish and categorise the information requirements to meet the needs of an organisations asset management system

**Operational stage/phase** The final stage in an assets development when the BIM data is used to manage all the information related to the operation and maintenance of the asset

**OPEX** Operational Expenditure, revenue expenditure incurred as a result of the day-to-day operations of an asset

**Orthophotographs** A two dimensional 'photo-map' image of an object, building or landscape where the scaling error caused by relief has been digitally removed through reference to an underlying 3D surface model

**Parametric modelling** The creation of a digital model based on a series of pre-programmed rules so that changes in design will automatically update the assembly and its components

**Parametric objects** Objects created using geometric definitions, associated data and rules that define their behaviour, how they interact with other objects or respond to changes in their parameters

**PDF** Portable Document Format, a file format used to present and exchange documents reliably, independent of software, hardware or operating system

**Photogrammetry** The art, science and technology of determining size, shape and identification of objects by analysing terrestrial or aerial imagery

**PIM** Project Information Model developed during the design and construction phase of a project which often forms the basis of the asset information model

**Plane table survey** One of the oldest forms of surveying comprising a tripod mounted drawing board and an alidade for sighting angle observations

**PLN** The proprietary file format used by ArchiCAD BIM authoring software

**Plug-ins** A software component that adds a specific feature to an existing computer program

**Point cloud** A collection of XYZ coordinates in a common co-ordinate system, that may also include additional information such as an intensity or RGB value, that portrays to the viewer an understanding of the spatial distribution of the surface of a subject

**Professional indemnity** Security or protection against loss, damage or other financial burden incurred by another individual as a result of professional services undertaken

**Professional liability** Legal obligations arising out of a professional's errors, acts of negligence or omissions during the course of their work

**Project north** The top of the drawing area within BIM authoring software

**PTS** 3D points file format for storing and transferring 3D points, which does not retain any original scan or registration information

**QA/QC** The combination of Quality Assurance, the systematic process used to measure a products desired level of quality and Quality Control, the process of ensuring it meets clients expectations

**RCP** The project file format used by Autodesk Recap that points to individual scan files and contains information about them

**RCS** The file format used by Autodesk Recap for a single point cloud scan

**ROI** Return On Investment, the gain or loss generated on an investment relative to the amount of money invested in it

**RVT** The proprietary file format used by Autodesk Revit BIM authoring software

**Scan-to-BIM** The process of creating, manipulating and placing native BIM components by directly referencing the underlying point cloud

**Schedule** listing of information in tabular format

**Tangible characteristics** Physical attributes that are quantifiable, measurable and factual

**TIFF** Tagged Image File Format, for storing and transferring raster images

**Total station** An electronic theodolite that combines horizontal and vertical angle observation with electromagnetic distance measurement (EDM)

**Traverse** A survey method requiring an identified starting point and orientation for establishing a common coordinate frame to locate observations from different stations relative to each other

**Vernacular** Historical style based on local needs, availability of construction materials and reflecting local traditions

**Viewports** A users visible area of a page which can be single or multiple depending on the available viewing hardware and the process being undertaken

**VRS** Virtual Reference Station, an imaginary unoccupied reference station for which observation data is created from the surrounding reference stations as though observed by a GNSS receiver

# 8 References

AIA 2013 *AIA® G202™-2013 Project Building Information Modelling Protocol Form*. AIA.  
<http://aiad8.prod.acquia-sites.com/sites/default/files/2016-09/AIA-G202-2013-Free-Sample-Preview.pdf>

AEC (UK) 2015 *AEC (UK) BIM Technology Protocol. Practical Implementation of BIM for the UK Architectural, Engineering and Construction (AEC) Industry*. AEC (UK).  
<https://aecuk.files.wordpress.com/2015/06/aecukbimtechnologyprotocol-v2-1-1-201506022.pdf>

Andrews, D, Bedford, J and Bryan, P 2015 *Metric Survey Specifications for Cultural Heritage*, 3rd edn. Swindon: Historic England.  
<https://content.historicengland.org.uk/images-books/publications/metric-survey-specifications-cultural-heritage/metric-survey-specifications-for-cultural-heritage-3rded.pdf>

APS Group Scotland 2013 *Review of Scottish Public Sector Procurement in Construction*. Edinburgh: The Scottish Government.  
<http://www.gov.scot/Resource/0043/00436662.pdf>

Aubin, P and Milburn, A 2013 *Renaissance Revit: Creating Classical Architecture with Modern Software*. Oak Lawn, IL: G3B Press

Beale and Co 2013 *Building Information Model (BIM) Protocol. Standard Protocol for Use in Projects using Building Information Models*. London: Construction Industry Council.  
<http://www.bimtaskgroup.org/wp-content/uploads/2013/02/The-BIM-Protocol.pdf>

Bedford, J and Papworth, H (eds) 2010 *Measured and Drawn: Techniques and Practice for the Metric Survey of Historic Buildings*, 2nd edn. Swindon: Historic England.  
<https://historicengland.org.uk/images-books/publications/measured-and-drawn/>

Brookes, C 2017 *The Application of Building Information Modelling (BIM) Within a Heritage Science Context*. Swindon: Historic England  
<http://research.historicengland.org.uk/Report.aspx?i=15603>

BSI 2007 *Collaborative Production of Architectural, Engineering and Construction Information: Code of Practice*. BSI Standards Publication **BS 1192:2007**. London: BSI.  
<https://www.thenbs.com/PublicationIndex/documents/details?Pub=BSI&DocId=285074>

BSI 2013a *Guide to the Conservation of Historic Buildings*. BSI Standards Publication **BS 7913:2013**. London: BSI.  
<https://www.thenbs.com/PublicationIndex/Documents/Details?DocId=305525>

BSI 2013b *Specification for Information Management for the Capital/Delivery Phase of Construction Projects using Building Information Modelling*. **PAS 1192-2:2013** Incorporating Corrigendum No. 1. London: BSI.  
<http://bim-level2.org/en/standards/>

BSI 2014a *Collaborative Production of Information. Fulfilling Employer's Information Exchange Requirements using COBie. Code of Practice*. BSI Standards Publication **BS 1192-4:2014**.  
<http://bim-level2.org/en/standards/>

BSI 2014b *Specification for Information Management for the Operational Phase of Assets using Building Information Modelling (BIM)*. **PAS 1192-3:2014**.  
<http://bim-level2.org/en/standards/>

Cabinet Office 2011 *Government Construction Strategy*. London: Cabinet Office.  
<https://www.gov.uk/government/publications/government-construction-strategy>

FISH 2017 *Forum on Information Standards in Heritage*.  
<http://heritage-standards.org.uk/fish-vocabularies/> (accessed March 2017)

Historic England 2002 *With Alidade and Tape: Graphical and Plane Table Survey of Archaeological Earthworks*. Swindon: Historic England.  
<https://historicengland.org.uk/images-books/publications/with-alidade-and-tape/>

Historic England 2005 *The Presentation of Historic Building Survey in Computer Aided Draughting*. Swindon: Historic England.  
<https://historicengland.org.uk/images-books/publications/historic-building-survey-in-cad/>



Historic England 2008 *Geophysical Survey in Archaeological Field Evaluation*. Swindon: Historic England.  
<https://historicengland.org.uk/images-books/publications/geophysical-survey-in-archaeological-field-evaluation/>

Historic England 2010 *The Light Fantastic: Using Airborne Lidar in Archaeological Survey*. Swindon: Historic England.  
<https://historicengland.org.uk/images-books/publications/light-fantastic/>

Historic England 2011 *3D Laser Scanning for Heritage: Advice and Guidance to Users on Laser Scanning in Archaeology and Architecture*, 2nd edn. Swindon: Historic England.  
<https://historicengland.org.uk/images-books/publications/3d-laser-scanning-heritage2/>

Historic England 2016a *Traversing The Past: The Total Station Theodolite In Archaeological Landscape Survey*, 2nd edn. Swindon: Historic England.  
<https://historicengland.org.uk/images-books/publications/traversingthepast/>

Historic England 2016b *Where On Earth Are We? The Role of Global Navigation Satellite Systems (GNSS) in Archaeological Field Survey*, 2nd edn. Swindon: Historic England.  
<https://historicengland.org.uk/images-books/publications/where-on-earth-gnss-archaeological-field-survey/>

Historic England 2017 *Photogrammetric Applications for Cultural Heritage*. Swindon: Historic England (forthcoming)

HM Government 2013 *Construction 2025. Industrial Strategy: Government Industry in Partnership*. London: HM Government.  
<https://www.gov.uk/government/publications/construction-2025-strategy>

ISO 2013 *ISO 16739:2013 Industry Foundation Classes (IFC) for Data Sharing in the Construction and Facility Management Industries*. Geneva: ISO.  
<https://www.iso.org/standard/51622.html>

Maxwell, I 2014 *Integrating Digital Technologies in Support of Historic Building Information Modelling: BIM4Conservation (HBIM). A COTAC Report*. London: COTAC.  
<http://cotac.global/resources/COTAC-HBIM-Report-Final-A-21-April-2014-2-small.pdf>

Maxwell, I 2016a *COTAC BIM4C Integrating HBIM Framework Report Part 1: Conservation Parameters*. London: COTAC.  
<http://cotac.global/resources/HBIM Framework Part 1 February 2016.pdf>

Maxwell, I 2016b *COTAC BIM4C Integrating HBIM Framework Report Part 1: Conservation Influences*. London: COTAC.  
<http://cotac.global/resources/HBIM Framework Part 2 February 2016.pdf>

Osello, A and Rinaudo, F 2016 'Cultural heritage management tools: the role of GIS and BIM, in Stylianidis, E and Remondino, F (eds) *3D Recording, Documentation and Management in Cultural Heritage*. Dunbeath: Whittles Publishing

# 9 Acknowledgements

## Case Studies

### Case Study 1 - A1 Leeming to Barton Project: Fort Bridge

Supplied by Dr Jonathan Shipley, Senior  
Archaeology and Heritage Consultant  
AECOM  
One Trinity Gardens, Quayside  
Newcastle upon Tyne NE1 2HF  
Tel: 0191 224 6658  
Email: [Jonathan.Shipley@aecom.com](mailto:Jonathan.Shipley@aecom.com)  
Web: [www.aecom.com](http://www.aecom.com)

### Case Study 2 - Edinburgh Waverley Railway Station

Supplied by Lee McDougall, Director  
AHR  
Norwich Union House, High Street  
Huddersfield  
West Yorkshire HD1 2LF  
Tel: 01484 537 411  
Email: [Lee.McDougall@ahr-global.com](mailto:Lee.McDougall@ahr-global.com)  
Web: [www.ahr-global.com](http://www.ahr-global.com)

### Case Study 3 - Woodseat Hall

Supplied by Jana Honkova, BIM Projects Manager  
Bridgeway Consulting Limited  
Bridgeway House, 2 Riverside Way  
Nottingham NG2 1DP  
Tel: 0115 919 1111  
Email: [Jana.Honkova@bridgeway-consulting.co.uk](mailto:Jana.Honkova@bridgeway-consulting.co.uk)  
Web: [www.bridgeway-consulting.co.uk](http://www.bridgeway-consulting.co.uk)

### Case Study 4 - The Oriental Club

Supplied by Steve Bury, Managing Director  
Bury Associates Limited  
Suite H2, Coventry Place, Blackpole East  
Worcester WR3 8SG  
Tel: 01905 930186  
Email: [Steve@buryassociates.co.uk](mailto:Steve@buryassociates.co.uk)  
Web: [www.buryassociates.co.uk](http://www.buryassociates.co.uk)

### Case Study 5 - The integration of meshed elements in a 3D BIM-ready model

**Case Study 6 - Measured building surveys to BIM**  
Both supplied by Charles Blockley, Senior  
Building Surveyor / Revit Technician  
Greenhatch Group Ltd  
Rowan House, Duffield Road, Little Eaton  
Derby DE21 5DR  
Tel: 01332 830044  
Email: [charlesb@greenhatch-group.co.uk](mailto:charlesb@greenhatch-group.co.uk)  
Web: [www.greenhatch-group.co.uk](http://www.greenhatch-group.co.uk)

### Case Study 7 - Public Areas and External Façade Laser Scanning and Revit Modelling

Supplied by Jenny Clark, Director, Mollenhauer  
Group & Fritz Panaligan, Estates Information and  
Innovation Manager, Natural History Museum  
Mollenhauer Group Ltd  
The Glove Factory Studios, Brook Lane  
Holt BA14 6RL  
Tel: 01225 784149  
Email: [jclark@mollenhauergroup.com](mailto:jclark@mollenhauergroup.com)  
Web: [www.mollenhauergroup.co.uk](http://www.mollenhauergroup.co.uk)

### Case Study 8 - IWM Lambeth Road laser scanning and modelling

Supplied by Nic Kljyn, CAD/ Survey Manager  
Stanburys Ltd  
25 Church Street  
Baldock  
Hertfordshire SG7 5AF  
Tel: 01462 894144  
Email: [nklyn@stanburys.com](mailto:nklyn@stanburys.com)  
Web: [www.stanburys.com](http://www.stanburys.com)

## Images

**Front Cover:** © Historic England

### Main Text

Figure 1: © Mark Bew and Mervyn Richards

Figure 2: Source HM Government (2013)

Figure 3: Source National Building Specification (NBS) Library

Figures 4 - 5: Source Brookes (2017)

© Historic England

Figure 6: Source Maxwell (2014) © COTAC

Figure 7: Source AEC (UK) 2015

Figure 8: © Historic England

Figure 9: Source PAS 1192-2:2013 (BSI 2013b)

© Mervyn Richards

Figures 10 - 11: Source PAS 1192-3:2014 (BSI 2014b) © The British Standards Institution 2014

### Case Studies

Figure CS1.1: © Highways England

Figure CS1.2: © Dr J P Shipley

Figure CS1.3: © AECOM/SWECO

Figures CS2.1 - CS2.2: © AHR

Figures CS3.1 - CS3.3: © Bridgeway Consulting Limited

Figures CS4.1 - CS4.4: © Bury Associates Limited

Figures CS5.1 - CS5.5: © Greenhatch Group Ltd

Figures CS6.1 - CS6.4: © Greenhatch Group Ltd

Figure CS7.1: © Mollenhauer Group Ltd

Figures CS8.1 - CS8.2: Stanburys Ltd

Every effort has been made to trace the copyright holders and we apologise in advance for any unintentional omissions, which we would be pleased to correct in any subsequent editions.

## Contact Historic England

East Midlands  
2nd Floor, Windsor House  
Cliftonville  
Northampton NN1 5BE  
Tel: 01604 735460  
Email: [eastmidlands@HistoricEngland.org.uk](mailto:eastmidlands@HistoricEngland.org.uk)

East of England  
Brooklands  
24 Brooklands Avenue  
Cambridge CB2 8BU  
Tel: 01223 582749  
Email: [eastofengland@HistoricEngland.org.uk](mailto:eastofengland@HistoricEngland.org.uk)

Fort Cumberland  
Fort Cumberland Road  
Eastney  
Portsmouth PO4 9LD  
Tel: 023 9285 6704  
Email: [fort.cumberland@HistoricEngland.org.uk](mailto:fort.cumberland@HistoricEngland.org.uk)

London  
1 Waterhouse Square  
138-142 Holborn  
London EC1N 2ST  
Tel: 020 7973 3700  
Email: [london@HistoricEngland.org.uk](mailto:london@HistoricEngland.org.uk)

North East  
Bessie Surtees House  
41-44 Sandhill  
Newcastle Upon Tyne NE1 3JF  
Tel: 0191 269 1255  
Email: [northeast@HistoricEngland.org.uk](mailto:northeast@HistoricEngland.org.uk)

North West  
3rd Floor, Canada House  
3 Chepstow Street  
Manchester M1 5FW  
Tel: 0161 242 1416  
Email: [northwest@HistoricEngland.org.uk](mailto:northwest@HistoricEngland.org.uk)

South East  
Eastgate Court  
195-205 High Street  
Guildford GU1 3EH  
Tel: 01483 252020  
Email: [southeast@HistoricEngland.org.uk](mailto:southeast@HistoricEngland.org.uk)

South West  
29 Queen Square  
Bristol BS1 4ND  
Tel: 0117 975 1308  
Email: [southwest@HistoricEngland.org.uk](mailto:southwest@HistoricEngland.org.uk)

Swindon  
The Engine House  
Fire Fly Avenue  
Swindon SN2 2EH  
Tel: 01793 445050  
Email: [swindon@HistoricEngland.org.uk](mailto:swindon@HistoricEngland.org.uk)

West Midlands  
The Axis  
10 Holliday Street  
Birmingham B1 1TG  
Tel: 0121 625 6870  
Email: [westmidlands@HistoricEngland.org.uk](mailto:westmidlands@HistoricEngland.org.uk)

Yorkshire  
37 Tanner Row  
York YO1 6WP  
Tel: 01904 601948  
Email: [yorkshire@HistoricEngland.org.uk](mailto:yorkshire@HistoricEngland.org.uk)



# Historic England

We are the public body that looks after England's historic environment. We champion historic places, helping people understand, value and care for them.

Please contact [guidance@HistoricEngland.org.uk](mailto:guidance@HistoricEngland.org.uk) with any questions about this document.

[HistoricEngland.org.uk](http://HistoricEngland.org.uk)

If you would like this document in a different format, please contact our customer services department on:

Tel: 0370 333 0607  
Fax: 01793 414926  
Textphone: 0800 015 0174  
Email: [customers@HistoricEngland.org.uk](mailto:customers@HistoricEngland.org.uk)

All information and weblinks accurate at the time of publication.

Please consider the environment before printing this document

HEAG154  
Publication date: v1.0 July 2017 © Historic England  
Design: Historic England

[<< Contents](#)